

User Manual



Solar Hybrid Inverter

HESP48160SH3 | HESP48180SH3 | HESP48200SH3



READ THE INSTRUCTIONS COMPLETELY BEFORE OPERATING THE EQUIPMENT

[Disregarding these instructions could result in permanent damage to the unit]

Due to product iteration and upgrade requirements, the equipment specifications, parameters and functional configurations are subject to timely updates and adjustments. The latest version of the user manual can be obtained via the official website: <https://www.szshuori.com>. We have made every effort to ensure the completeness and accuracy of the content in this document; however, SRNE reserves the right to modify product and document content without prior notice.

Users must strictly follow the provisions of this manual throughout the entire process of equipment installation, operation and maintenance. SRNE shall not be liable for any consequences arising from failure to operate in accordance with the requirements specified in this manual. Meanwhile, SRNE shall only be responsible for the inverter equipment supplied herewith, and shall not assume joint and several liability for any associated upstream or downstream systems related to the equipment.

The Company shall not be liable for damage caused by :

- ① Damage caused by improper use or use in a wrong location.
- ② PV modules with an open-circuit voltage exceeding the maximum permissible voltage.
- ③ Damage caused by the operating temperature exceeding the restricted operating temperature range.
- ④ Dismantling and repair of the inverter by unauthorised persons.
- ⑤ Damage caused by force majeure: damage during transport or handling of the inverter.



Please scan the QR code
to download the user manual

Contents

1.Safety Precautions	4
1.1 How to Use This Instruction Manual	4
1.2 Symbols in This Manual	4
1.3 Safety Instructions	4
2.Product Introduction	5
2.1 Product Description	5
2.2 Product Features	5
2.3 System Connection Diagram	6
2.4 Product Overview	8
2.5 Product Size	9
3.Installation	10
3.1 Installation List	10
3.2 Installation Instructions	11
3.2.1 Installation Location Selection	11
3.2.2 Mounting the Inverter	12
3.2.3 Removing the Terminal Protection Cover	13
4.Connection Instructions	13
4.1 Single-Phase or Three-Phase Mode	13
4.2 Cable & Circuit Breaker Selection	14
4.3 Grid & Load & Generator Connection	15
4.4 Battery Connection	16
4.5 PV Connection	17
4.6 Dry Contact Connection	19
4.7 Grounding Connection	19
4.8 Inverter Start-Up	20
4.9 Parallel Connection	20
4.9.1 Introduction to Parallel Connection.....	20
4.9.2 Precautions for Parallel Connection Cables	20
4.9.3 Schematic of Three-Phase Parallel Operation	21
5.Operation	26
5.1 Operation and Display Panel	26
5.2 Setting Parameters	30
5.2.1 Basic Setup	31
5.2.2 Work Mode Setup	31
5.2.3 Battery Setup	34
5.2.4 Grid Connection Setup	36
5.2.5 Advanced Setup	39
5.2.6 WiFi Setup	41
5.2.7 Firmware Upgrade via USB Drive	42
5.3 Time-slot Charging/Discharging Function	43
5.4 Battery Parameters	44
5.4.1 Lead-acid Battery	44
5.4.2 Lithium-ion Battery	44
6.Communication	45
6.1 Product Overview	45
6.2 USB-1 Port	46
6.3 WiFi Communication Function	46
6.4 RS485 Port	47
6.5 CAN Port	47
6.6 Display Port USB-2	47
6.7 DRM(Only Australia)	47
6.8 External CT Prot	48
6.9 DIP Switch Configuration	49
6.10 Dry Contact Function	49
6.11 Remote Monitoring	49
6.11.1 Download App	50
6.11.2 Stick Logger Installation	50
6.11.3 SOLARMAN Smart APP Operation	51
6.11.4 Plant Detail	53
6.11.5 Abnormal State Processing	55
7.Fault and Remedy	56
7.1 Fault Codes	56
7.2 Troubleshooting	58
8.Protection and Maintenance	59
8.1 Protection Functions	59
8.2 Maintenance	60
8.3 Storage	61
9.Datasheet	61

1. Safety Precautions





1.1 How to Use This Instruction Manual

This manual contains important information, guidelines, operation and maintenance for the following products:

HESP Series: 48160SH3, 48180SH3, 48200SH3.

Read the manual and other related documents before performing any operation on the inverter. Documents must be stored carefully and be available at all times.

1.2 Symbols in This Manual

 DANGER	<p>DANGER indicates a hazardous situation which, if not avoided, will result in death or serious injury.</p>
 WARNING	<p>WARNING indicates a potentially hazardous situation which, if not avoided, could result in death or serious injury.</p>
 CAUTION	<p>CAUTION indicates a potentially hazardous situation which, if not avoided, may result in minor or moderate injury.</p>
 NOTICE	<p>NOTICE provides important information related to the operation of the product.</p>

1.3 Safety Instructions

WARNING: This chapter contains important safety and operating instructions. Read and keep this manual for future reference.

- Be sure to comply the local requirements and regulation to install this inverter.
- Beware of high voltage. Please turn off the switch of each power sources before and during the installation to avoid electric shock.
- For optimum operation of this inverter, please follow required specification to select appropriate cable size and necessary protective device.
- Do not connect or disconnect any connections when the inverter is working.
- Do not open the terminal cover when the inverter working.
- Make sure the inverter is well grounding.
- Never cause AC output and DC input short circuited.
- Do not disassembly this unit, for all repair and maintenance, please take it to the professional service center.
- Never charge a frozen battery.

2. Product Introduction

2.1 Product Description

The HESP48XXXSH3 series is a new type of solar energy storage inverter that integrates solar energy storage, utility charging, energy storage, and AC sine wave output.

It is highly compatible with various application scenarios, including residential energy storage systems.

It adopts DSP control and achieves high response speed, reliability, and compliance with an industrial standard through an advanced control algorithm. It provides users with a reliable and efficient energy conversion solution.

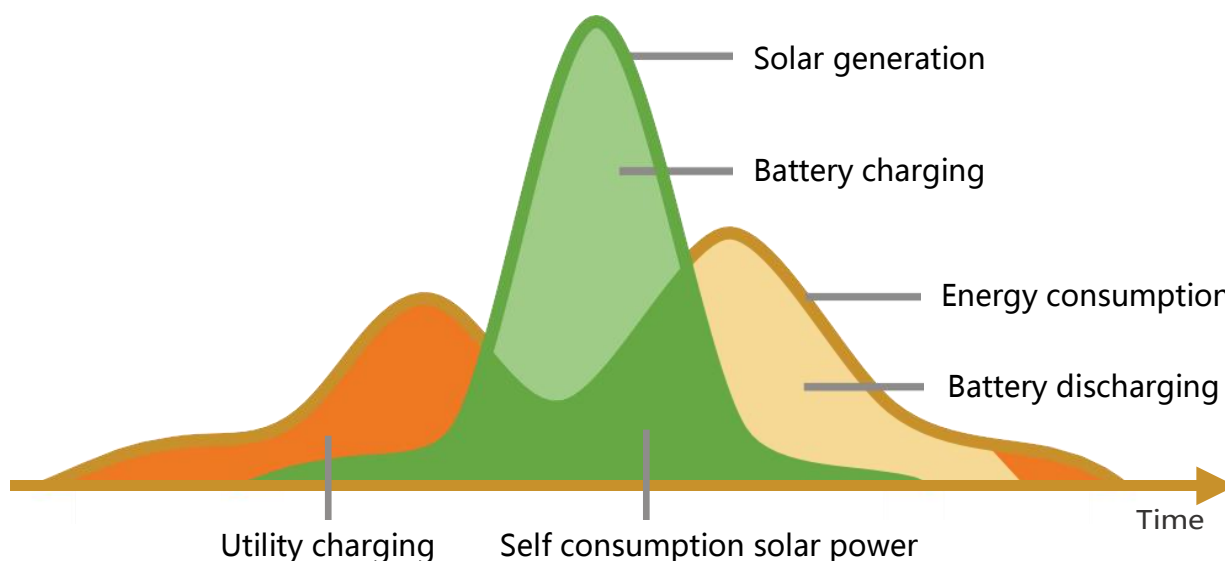

2.2 Product Features

- Supports lead-acid battery and li-ion battery connections.
- Supports smart load function with intelligent load connection control based on battery status.
- Supports AC coupling function for flexible integration into existing PV systems.
- With PV activation function when the li-ion battery is dormant; PV power input can trigger activation of the li-ion battery.
- Support three-phase pure sine wave output (305~485V).
- 100% three-phase unbalanced output, with each phase output power reaching over 50% of the rated power.
- Supports phase voltage adjustment in the range of 200, 208, 220, 230, 240Vac.
- Supports three PV inputs, with the function of simultaneously tracking the maximum power charging or carrying capacity of three MPPT.
- Three-channel MPPT, efficiency up to 99.9%, single maximum current of 26A, perfectly adapted to high-power modules.

- Supports multiple charging modes: Solar-only charging, grid & PV hybrid charging, diesel generator charging, etc.
- With time-slot charging and discharging setting function, it helps users to take advantage of peak and valley tariffs and save electricity costs.
- Energy-saving mode function to reduce no-load energy losses.
- With two output modes of utility bypass and inverter output, with uninterrupted power supply function.
- LCD large screen dynamic flow diagram design, easy to understand the system data and operation status.
- Multi-functional protection logic, including short-circuit protection, overcurrent protection, overvoltage protection, undervoltage protection, overload protection, and over-temperature protection.
- Support CAN, USB, and RS485 communication.

2.3 System Connection Diagram

The diagram below shows the system application scenario of this product. A complete system consists of the following components:

- **PV Modules:** Converts light energy into DC energy, which can be used to charge the battery via an inverter or directly inverted into AC power to supply the load.
- **Grid:** Connected to the mains AC input, supplying power to loads while charging batteries. The system can operate off-grid when batteries and PV modules power the loads.
- **Battery:** The role of the battery is to ensure the normal power supply of the system loads in case of insufficient photovoltaic and no utility power.
- **Home Load:** Connects to a variety of home and office loads including refrigerators, lamps, TVs, fans, air conditioners and other AC loads.
- **Generator/Smart Load/Micro-Inverter Input:** When connected to an AC generator, supplies power to loads and charges batteries simultaneously. Without generator connection, this interface can be configured as a Smart load output to power loads. When connected to micro-inverters, it supplies power to loads and charges batteries concurrently.
- **Inverter:** It is the energy conversion device of the whole system.

Note: The actual application scenario determines the specific system cabling.

System Wiring Diagram 1

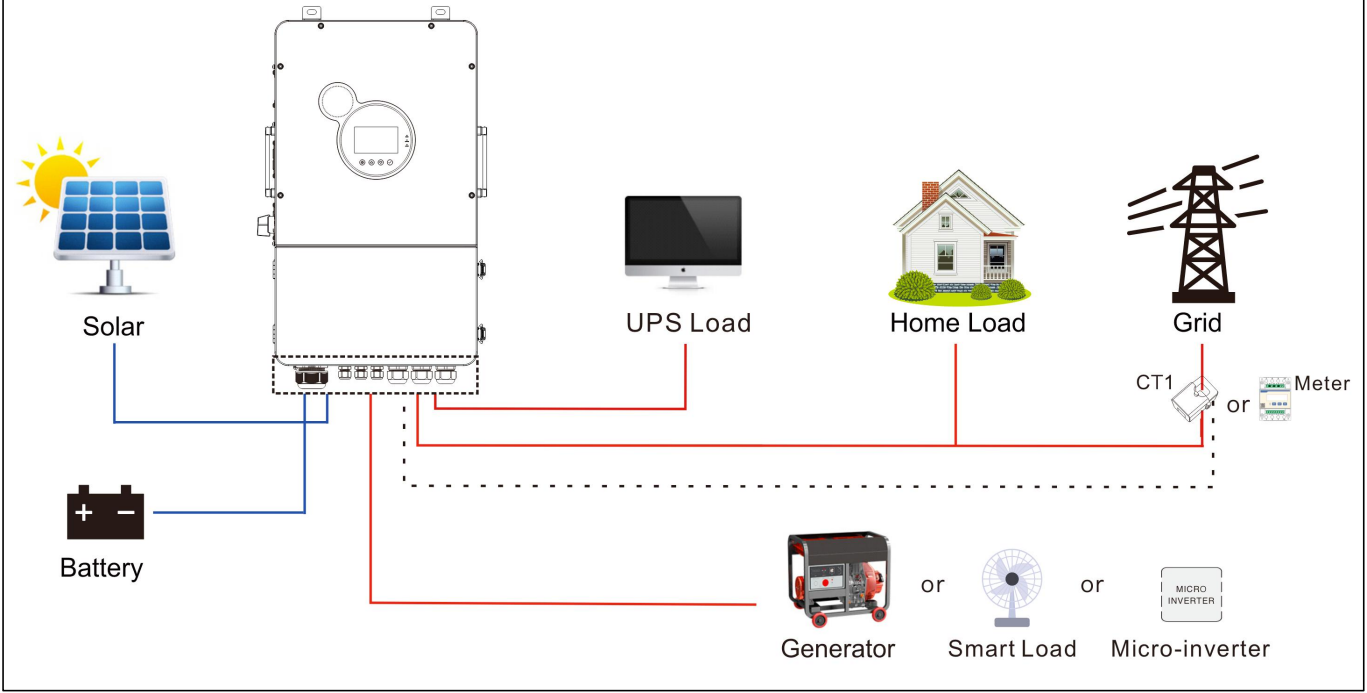

System Wiring Diagram 2

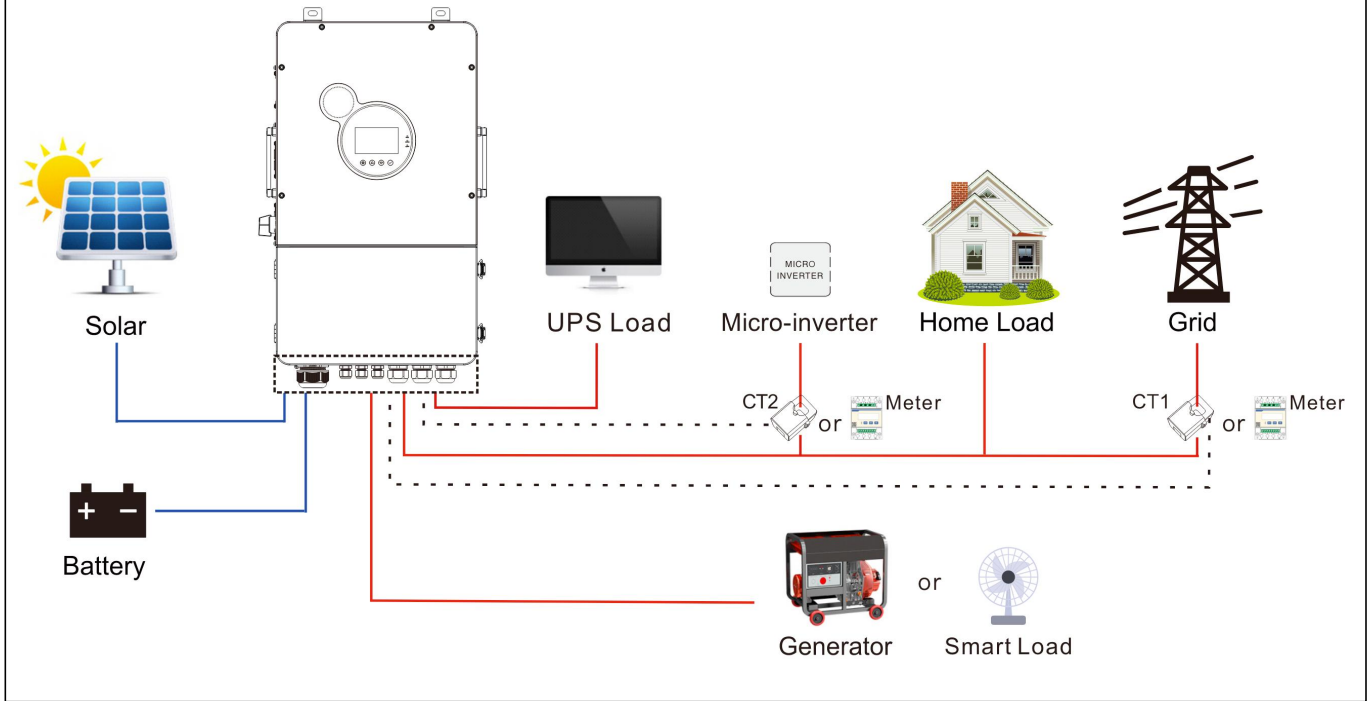

2.4 Product Overview

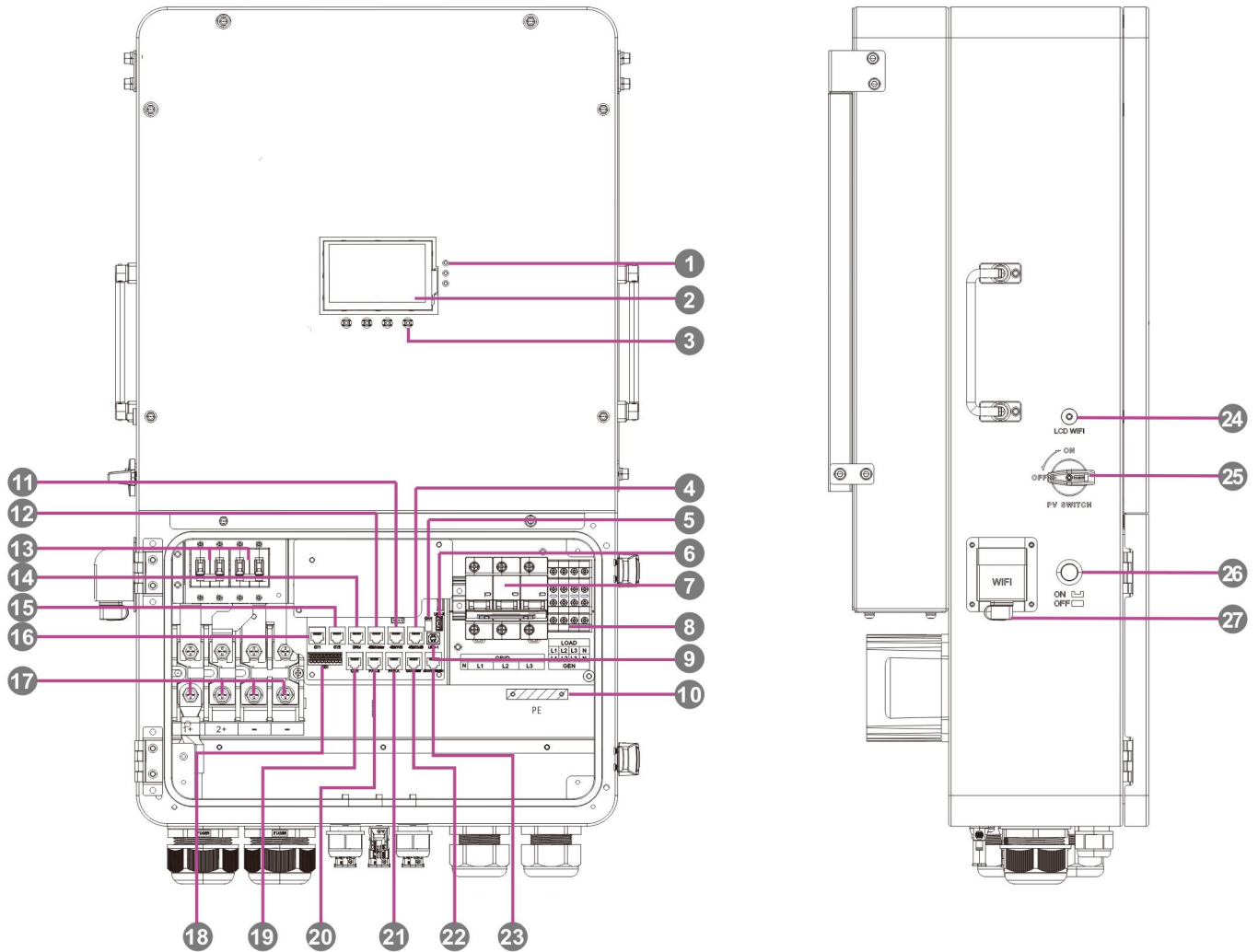

1	LED Indicators	2	LCD Screen	3	Operation Buttons
4	485/EMS Port	5	Parallel DIP Switch	6	Display USB-2
7	Grid Circuit Breaker (L1+L2+L3+N)	8	Load/Generator Terminals (L1+L2+L3+N)	9	Communication Port USB-1
10	Grounding Copper Busbar	11	485/WiFi Port	12	485/Meter Port
13	Battery Circuit Breaker	14	DRM Port	15	Micro-Inverter CT2
16	Grid CT1	17	Battery Connection Screws	18	Dry Contact Interface SC1
19	CAN2 Communication Port	20	Parallel Port - B	21	Parallel Port - A
22	CAN2/BMS2 Communication Port	23	CAN3/485/BMS1 Communication Port	24	Display WiFi Interface
25	PV Input Switch	26	Operation Switch	27	WiFi Module



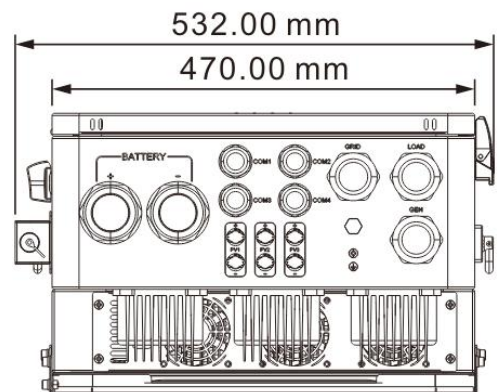
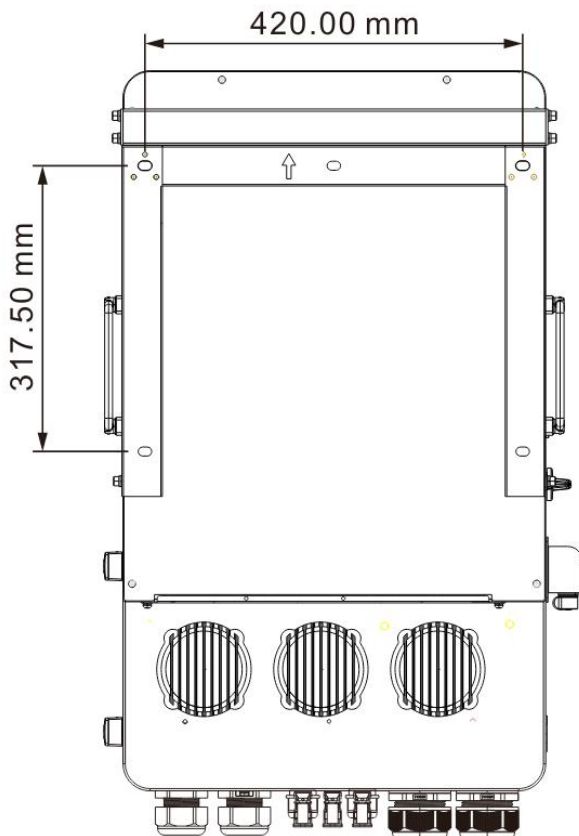
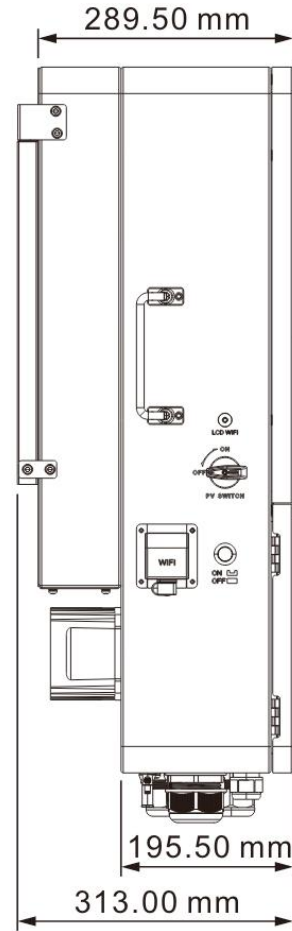
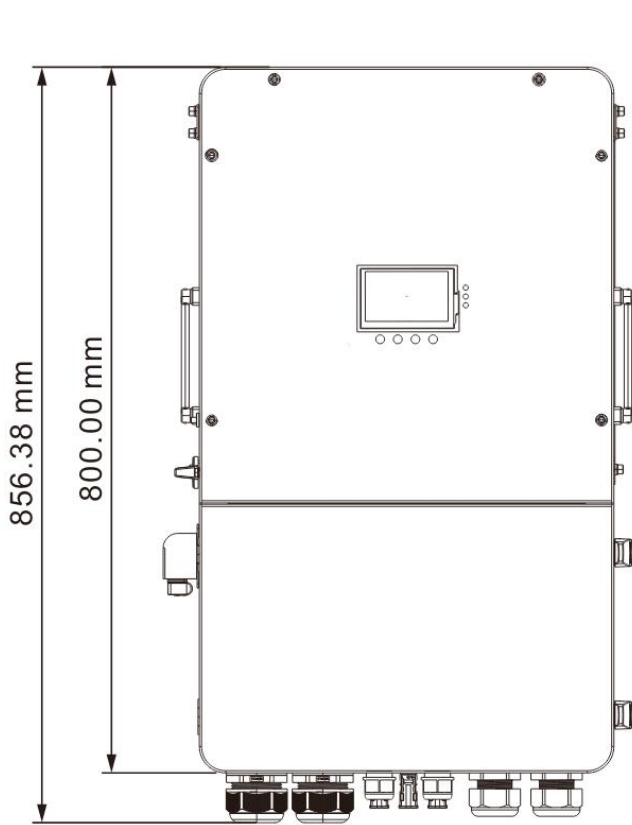



2.5 Product Size

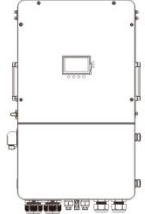

3. Installation

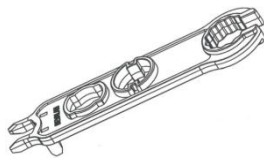
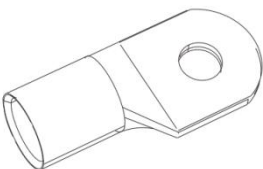
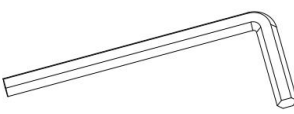
3.1 Installation List

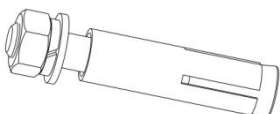
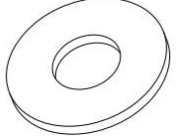
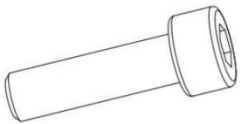
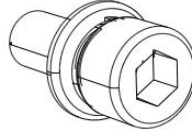
Please check the equipment before installation. Make sure that there is no damage to the packaging. You should have received the following items in the package:

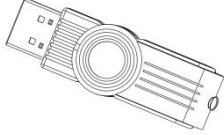
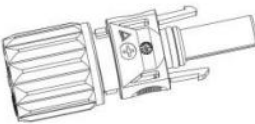
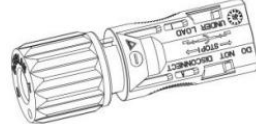
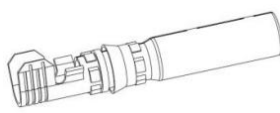
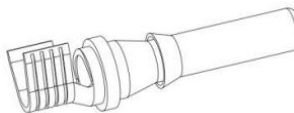
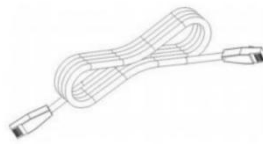
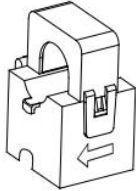
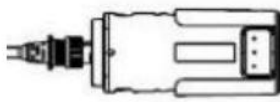
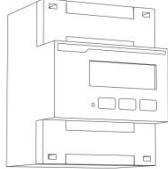
 <p>Hybrid inverter x 1pcs</p>	 <p>Wall mount bracket x 1pcs</p>	 <p>MC4 unlocking tool x 1pcs</p>	 <p>Cold-pressed terminal SC95-10 x 4pcs</p>
 <p>Hex wrench L-shaped_5mm x 1pcs</p>	 <p>M8 socket wrench x 1pcs</p>	 <p>Expansion screws M8*60mm x 5pcs</p>	 <p>M8 flat washer x 5pcs</p>
 <p>Spare screw M6*18mm x 1pcs</p>	 <p>Hex socket head triple-combination screws M6x12 x 2pcs</p>	 <p>Keys x 4pcs</p>	 <p>USB flash drive x 1pcs</p>
 <p>PV+ terminal x 3pcs</p>	 <p>PV- terminal x 3pcs</p>	 <p>PV+ input metal core x 3pcs</p>	 <p>PV- input metal core x 3pcs</p>
 <p>Parallel connection cable x 1pcs</p>	 <p>CT x 1pcs</p>	 <p>WiFi module x 1pcs</p>	 <p>Three-phase meter (Optional) x 1pcs</p>

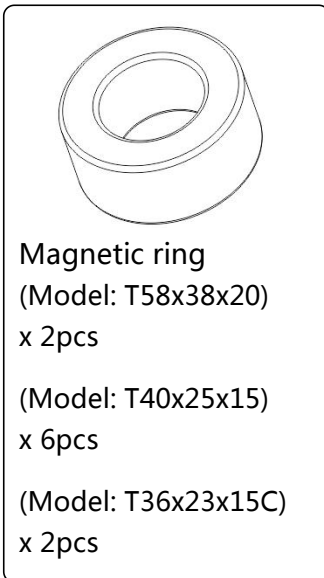
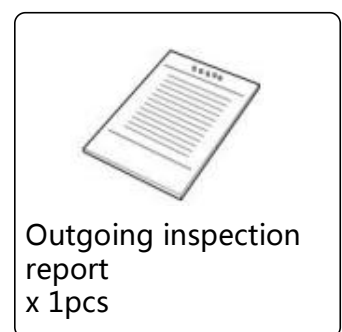
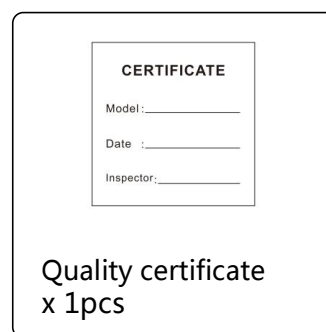
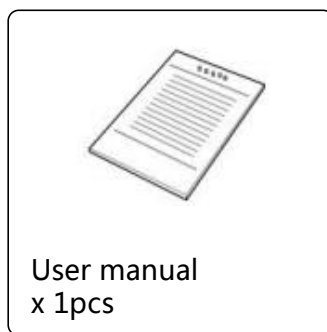
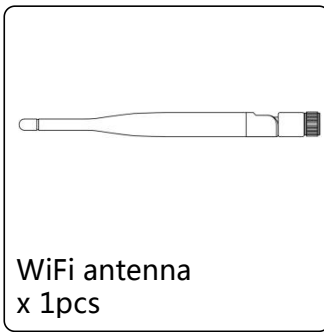

 **NOTICE**

Introduction: Anti-interference magnetic rings

Function: When external wiring is long or there is uncertain electromagnetic interference in the usage environment, it is recommended to install magnetic rings on the wires. Magnetic rings can be directly slipped onto the wires or wrapped around them in a single loop.

- 2 magnetic rings of model T58x38x20, primarily used on the battery side to suppress interference generated during battery charging and discharging.
- 6 magnetic rings of model T40x25x15, primarily used on power lines for mains power, generator loads, and photovoltaic systems to suppress external interference.
- 2 magnetic rings of model T36x23x15C, primarily used to be fitted onto various communication lines (such as WiFi lines, external CT lines, parallel machine lines, 485 lines, CAN lines, etc.) to suppress interference during signal transmission.

3.2 Installation Instructions

3.2.1 Installation Location Selection

The HESP48XXXSH3 series can be used outdoors (protection class IP65). Please consider the followings before selecting the location:

- Choose the solid wall to install the inverter.
- Mount the inverter at eye level.
- Adequate heat dissipation space must be provided for the inverter. (specific requirements: the heat dissipation distance above and below the inverter should be $\geq 500\text{mm}$), and the distance on both left and right sides should be $\geq 200\text{mm}$).
- The ambient temperature should be between $-40\sim 60^{\circ}\text{C}$ ($-40\sim 140^{\circ}\text{F}$) to ensure optimal operation.

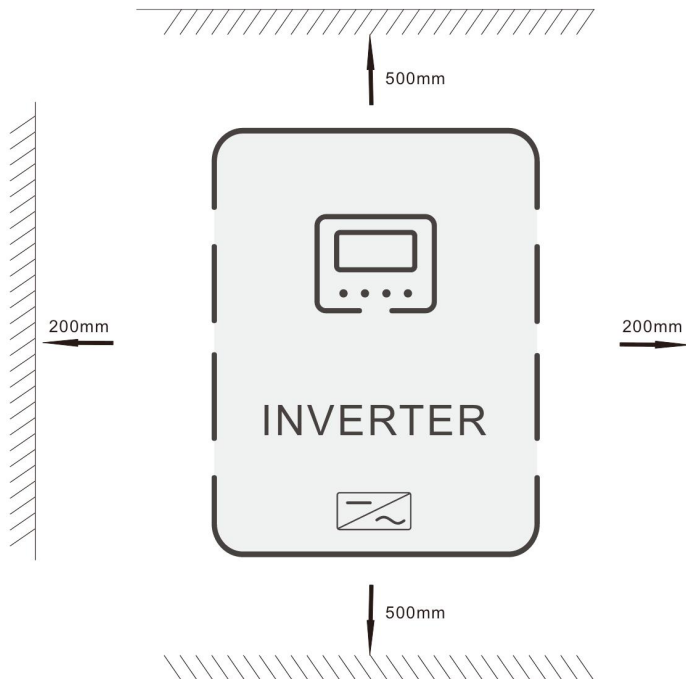
⚠ DANGER

- Do not install the inverter where highly flammable materials are near by.
- Do not install the inverter in potential explosive areas.
- Do not install the inverter with lead-acid batteries in a confined space.

⚠ CAUTION

- Do not install the inverter in direct sunlight.
- Do not install or use the inverter in a humid environment.

3.2.2 Mounting the Inverter

- **Step 1:** Determine the positions for drilling holes, ensure the position of holes are level, then mark them with a marker pen, use the hammer drill to drill holes on the wall. Keep the hammer drill perpendicular to the wall, do not shake when drilling, so as not to damage the wall. If the error of the hole is too big, you need to reposition.
- **Step 2:** Insert M8*60 expansion bolt vertically into the hole and pay attention to the insertion depth of the expanding bolt (should be deep enough)
- **Step 3:** Align the wall hanger with the position of holes, fix the wall hanger on the wall by tightening the expansion bolt with nuts.
- **Step 4:** Align the mounting holes and attach the inverter to the wall bracket, securing it in place with safety screws.

Step 1

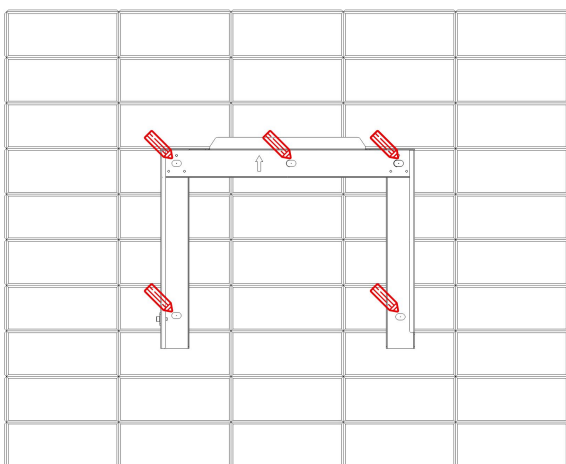

Step 2

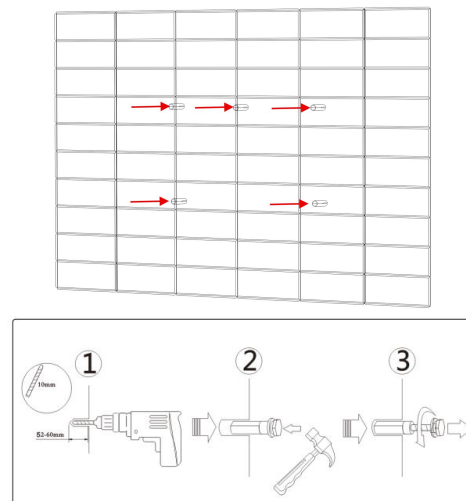

Step 3

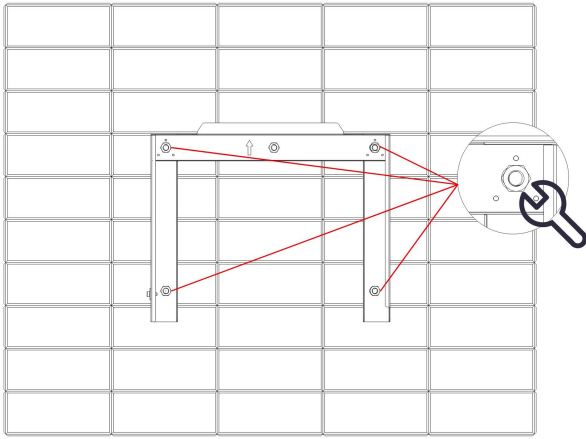

Step 4

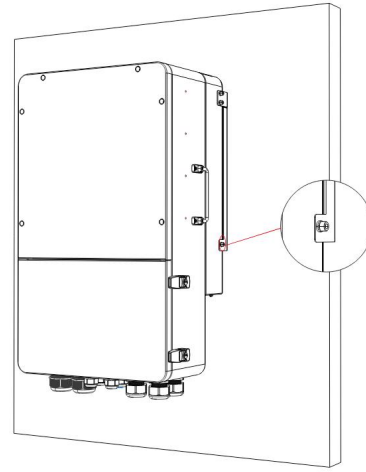

3.2.3 Removing the Terminal Protection Cover

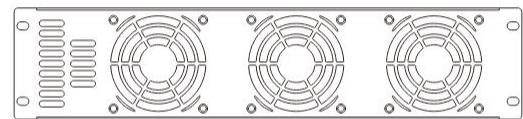
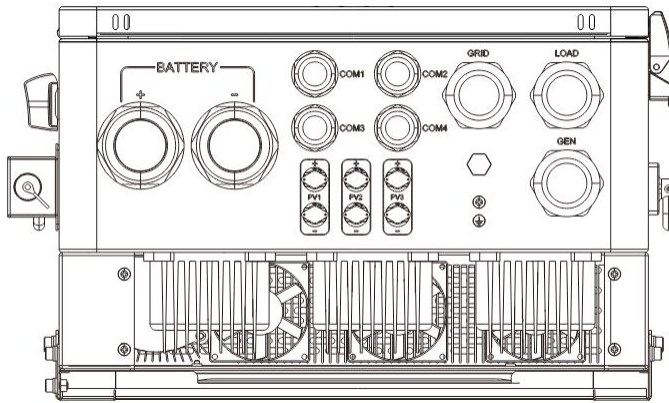

Fan cover removable for cleaning

NOTICE

When using the device in areas with poor air quality, the dust screen is easily blocked by air particles. Please disassemble and clean the dust screen periodically to avoid affecting the internal air flow rate of the inverter, which may trigger an over-temperature protection fault (19/20 fault) affecting the use of the power supply and the service life of the inverter.

4.Connection Instructions

4.1 Single-Phase or Three-Phase Mode

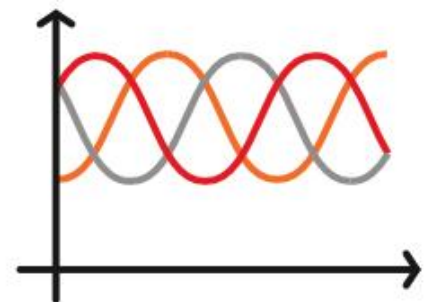
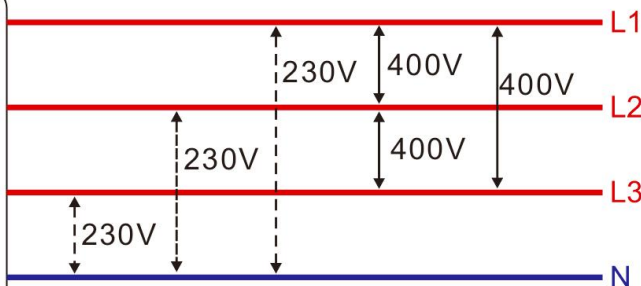
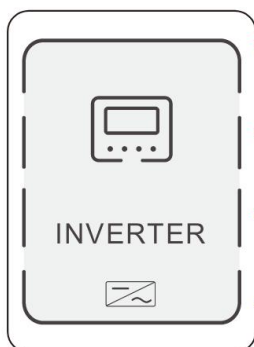

Three phase output

Items	Description
Applicable model	HESP series SH3 model
AC output phase voltage (L-N)	200~240Vac, 230Vac default

 **NOTICE**

- Users can change the output voltage through the settings menu. For details, refer to Chapter 5.2.
- The output voltage corresponds to parameter setting item **【Work Mode】 - 【Output Voltage】** , and the output phase voltage can be set within the range of 200V to 240V.

4.2 Cable & Circuit Breaker Selection

■ PV Input

Models	Cable Diameter	Max. Input Current	Circuit Breaker Specifications
HESP48160SH3	5mm ² / 10 AWG	26A	2P-32A
HESP48180SH3	5mm ² / 10 AWG	26A	2P-32A
HESP48200SH3	5mm ² / 10 AWG	26A	2P-32A

■ Battery

Models	Cable Diameter	Max. Input Current	Circuit Breaker Specifications
HESP48160SH3	67mm ² / 00 AWG	150*2A	2P-200A
HESP48180SH3	67mm ² / 00 AWG	165*2A	2P-200A
HESP48200SH3	67mm ² / 00 AWG	175*2A	2P-200A

■ Grid

Models	Output Mode	Cable Diameter	Max. Input Current	Circuit Breaker Specifications
HESP48160SH3	Three-phase	21mm ² /6AWG(L1/L2/L3/N)	70A	4P-100A
HESP48180SH3	Three-phase	21mm ² /6AWG(L1/L2/L3/N)	70A	4P-100A
HESP48200SH3	Three-phase	21mm ² /6AWG(L1/L2/L3/N)	70A	4P-100A

■ Generator

Models	Output Mode	Cable Diameter	Max. Input Current	Circuit Breaker Specifications
HESP48160SH3	Three-phase	21mm ² /6AWG(L1/L2/L3/N)	70A	4P-100A
HESP48180SH3	Three-phase	21mm ² /6AWG(L1/L2/L3/N)	70A	4P-100A
HESP48200SH3	Three-phase	21mm ² /6AWG(L1/L2/L3/N)	70A	4P-100A

■ Load

Models	Output Mode	Cable Diameter	Max. Output Current	Circuit Breaker Specifications
HESP48160SH3	Three-phase	21mm ² /6AWG(L1/L2/L3/N)	70A	4P-100A
HESP48180SH3	Three-phase	21mm ² /6AWG(L1/L2/L3/N)	70A	4P-100A
HESP48200SH3	Three-phase	21mm ² /6AWG(L1/L2/L3/N)	70A	4P-100A

NOTICE

● **AC input, and AC output:**

- ① Use a stripper to remove the 6-8mm insulation of the cable.
- ② Fixing a ferrule at the end of the cable (ferrule needs to be prepared by the user).

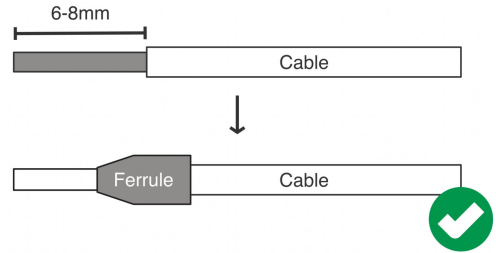

● **Battery:**

- ① Use a stripper to remove the 6-8mm insulation of the cable.
- ② Fixing cable lugs that supply with the box at the end of the cable.

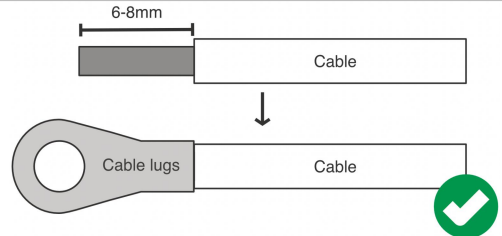

Wire diameter specifications are for reference only. For longer distances between the PV array and inverter, or between the inverter and batteries, use thicker wires to reduce voltage drop and improve system performance.

4.3 Grid & Load & Generator Connection

Connect the live, neutral and ground cables in the position and order of the cables as shown in the diagram below.

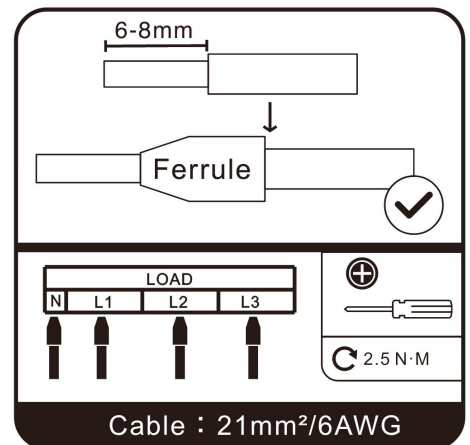
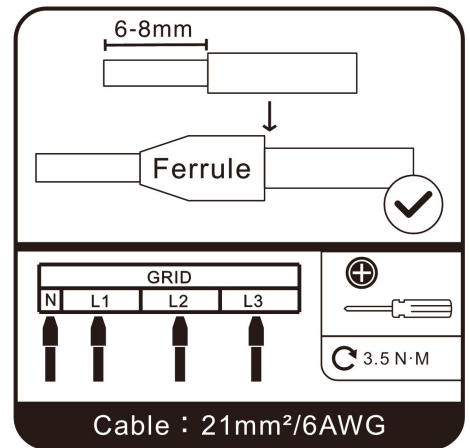
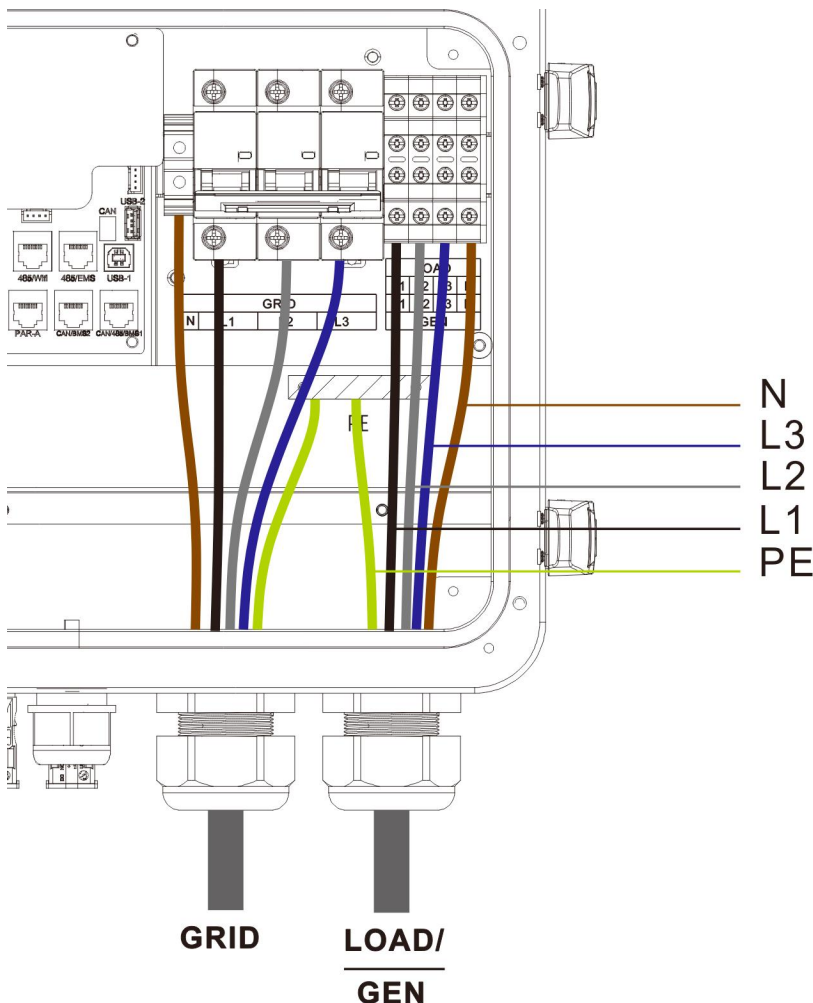

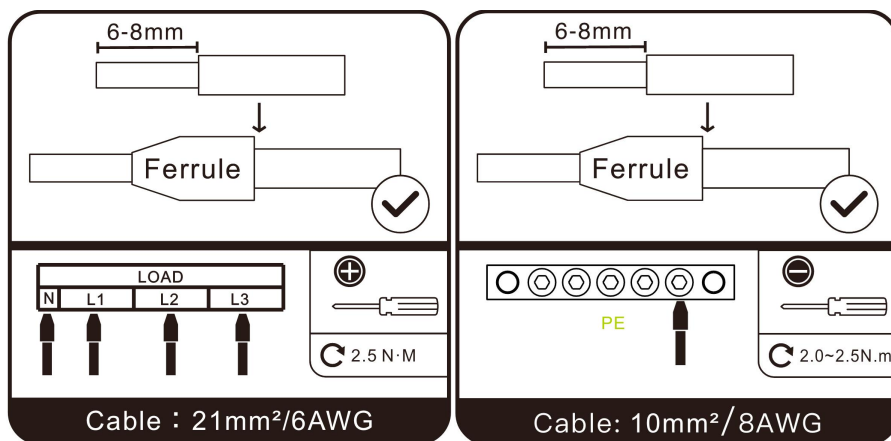

⚠ DANGER

- Before connecting AC input and output, the circuit breaker must be turned off to avoid electric shock hazards, and never operate with electricity.
- Please check that the cable used is sufficient for the requirements, too thin, poor quality cables are a serious safety hazard.

4.4 Battery Connection

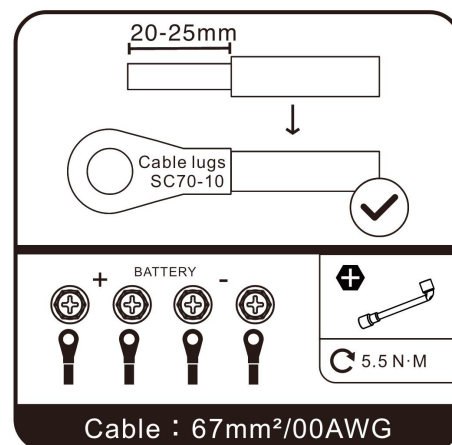
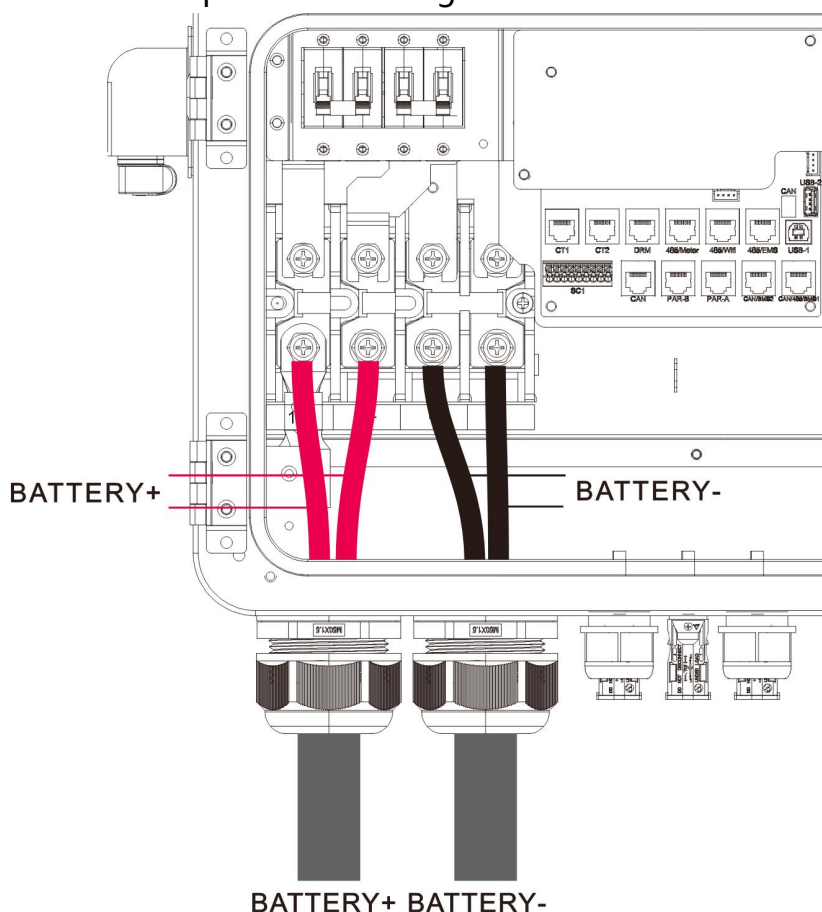
Connect the positive and negative cable of the battery according to the diagram below.

⚠ DANGER

- Before connecting the battery, the circuit breaker must be turned off to avoid electric shock hazards, and never operate with electricity.
- Confirm the positive and negative poles of the battery according to the markings to ensure correct connection, avoiding inverter damage caused by reverse polarity.
- Verify the cable specifications and parameters, and select cables that meet the rated current and voltage transmission requirements of the equipment. Cables with too small diameter or substandard insulation shall be forbidden.
- The connection cables from the two battery sets to the inverter should be kept as consistent in length as possible to avoid uneven current distribution caused by line impedance differences, which may affect the overall system performance.

4.5 PV Connection

1. Before connecting PV, first close the external circuit breaker and make sure the cable used is sufficiently thick. Please refer to Chapter "4.2 Cable & Circuit Breaker Selection".
2. Correctly connect the PV input wires according to the cable sequence and terminal positions shown in the figure below. When using in parallel, different machines need to be connected to different PV arrays or PV sources.

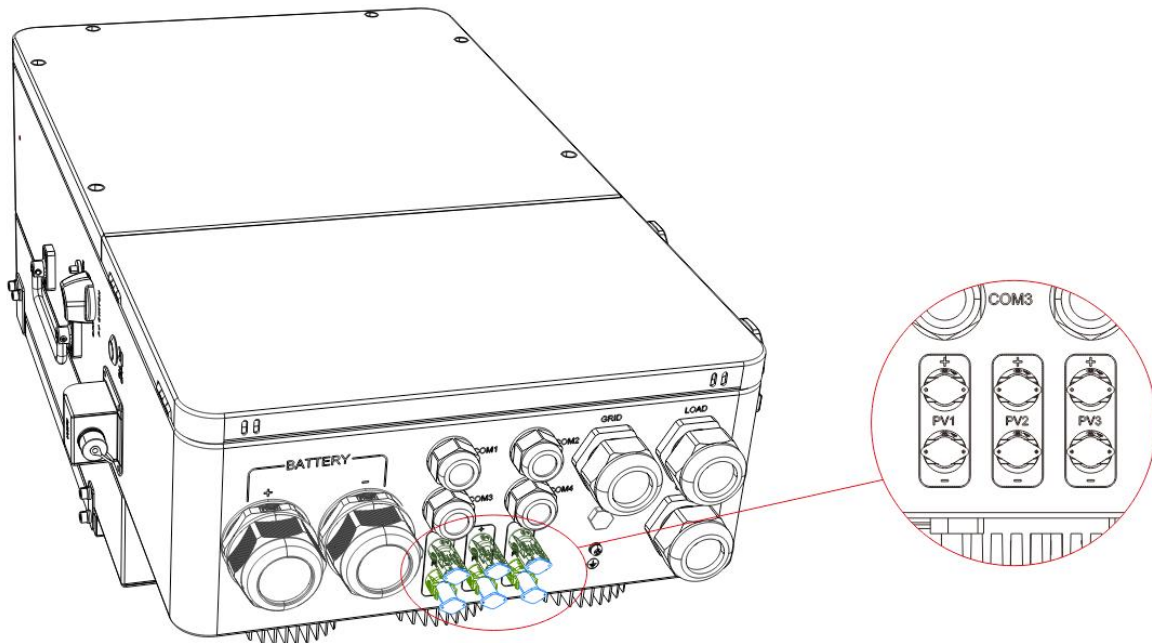

<p>① Positive pole metal ② Negative pole metal</p>	<p>Press the wire by crimping tool</p>	<p>③ Positive terminal ④ Negative terminal Insert until a "click" sound is heard</p>
<p>Tighten terminal</p>	<p>Connect to the inverter prot</p>	<p>Disconnect PV terminal</p>

DANGER

- Before connecting the PV, the circuit breaker must be turned off to avoid electric shock hazards, and never operate with electricity.
- Make sure that the open-circuit voltage of the PV modules connected in series does not exceed the max. open-circuit voltage of the inverter (the value is 1000V), otherwise the inverter may be damaged.

Transmitter-PLC Device (Option)

The inverter includes a rapid shutdown system that complies with 2017 and 2020 NEC 690.12 requirements. A rapid shutdown switch should be connected to the RSD terminals on the inverter and mounted on a readily accessible location outdoors (check with your AHJ for requirements).

The APsmart Rapid Shutdown System Transmitter-PLC is part of a rapid shutdown solution when paired with APsmart RSD, a PV module rapid shutdown unit. While powered on, the Transmitter-PLC sends a signal to the RSD units to keep their PV modules connected and supplying energy. RSD units automatically enter rapid shutdown mode when the Transmitter-PLC is switched off and resume energy production when power is restored to the Transmitter-PLC.

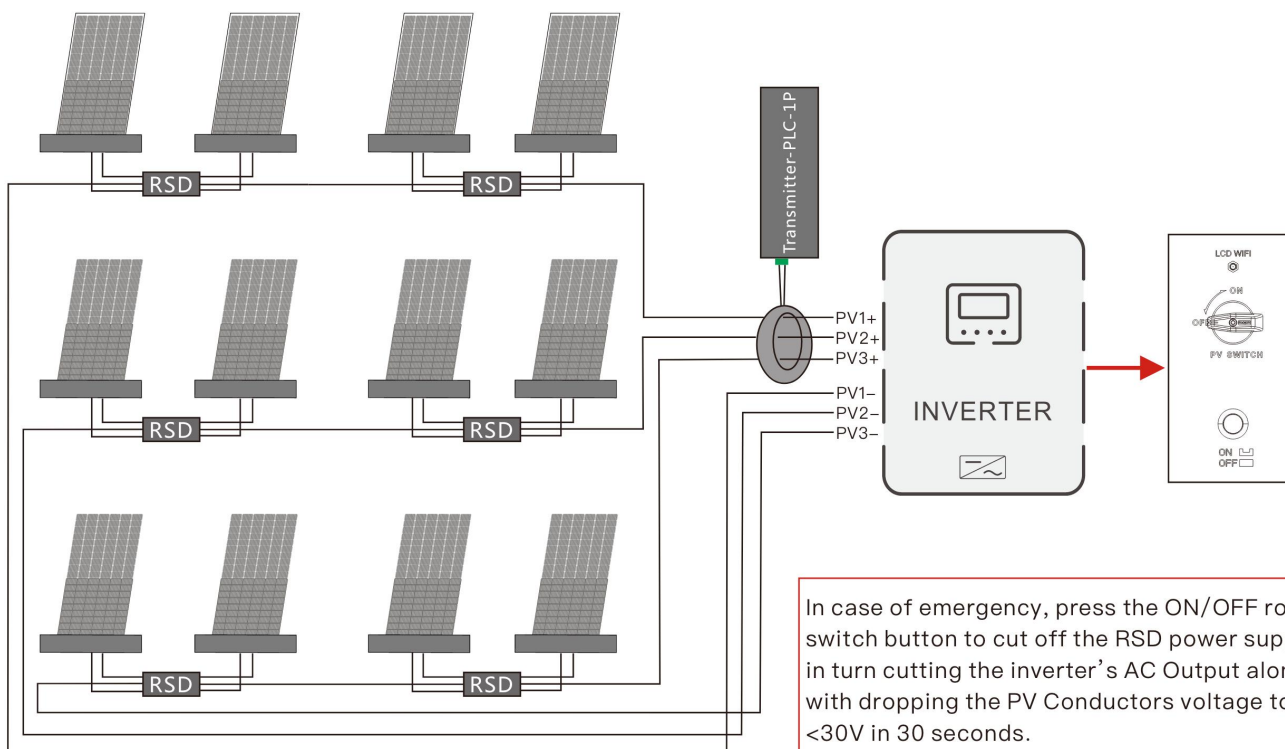

4.6 Dry Contact Connection

Use a small screwdriver to push backward in the direction of the arrow, and insert the communication cable into the dry contact port.

Communication cable diameter: 0.2~1.5mm²

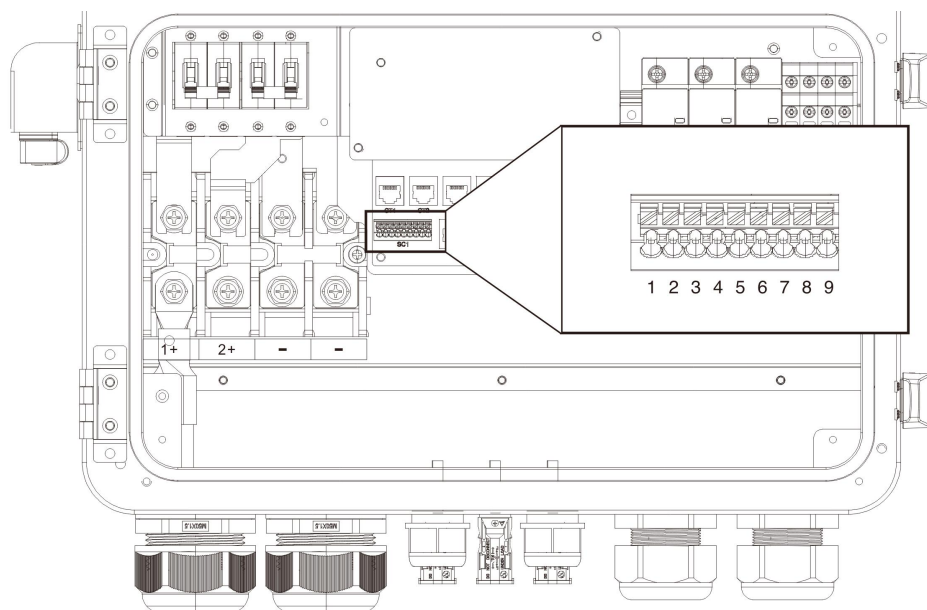

4.7 Grounding Connection

Please make sure the grounding terminal connect to the Grounding Bar.

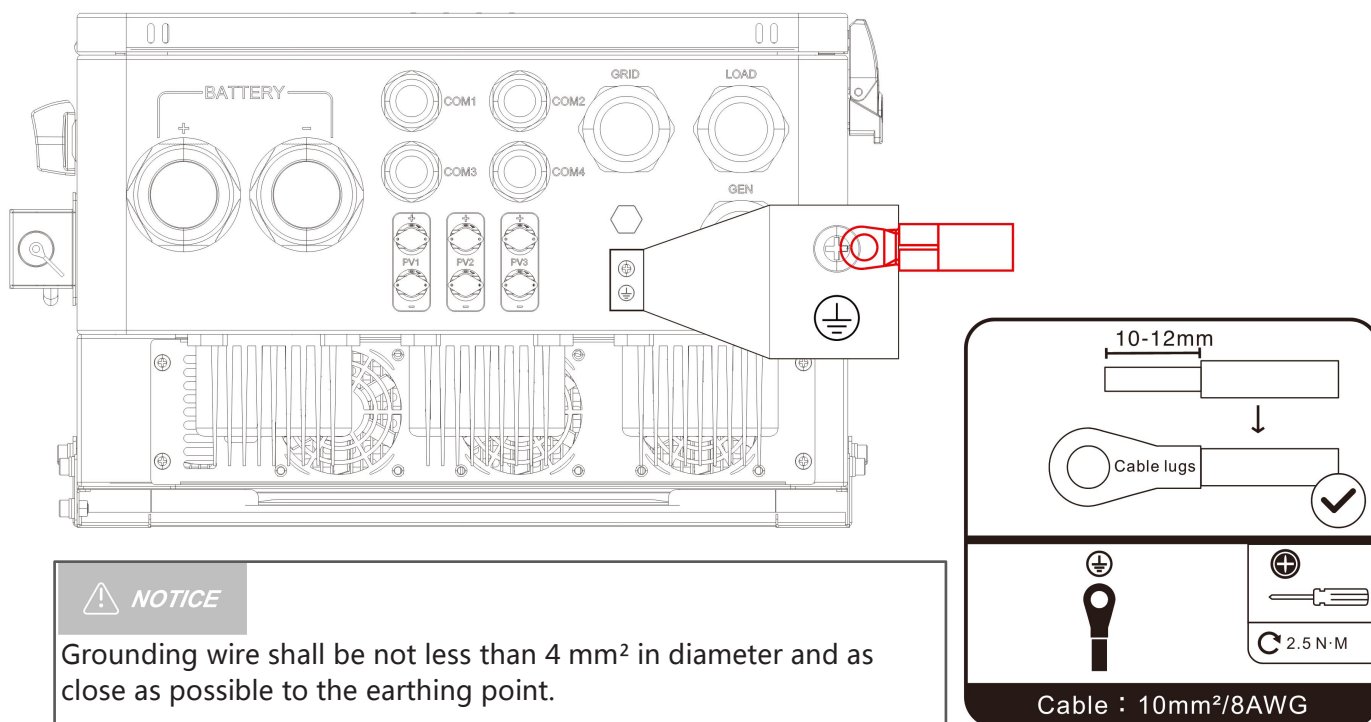

4.8 Inverter Start-Up

After ensuring that the wiring is reliable and the wire sequence is correct, restore the terminal protection cover to its original position.

- **Step 1:** Close the circuit breaker of the battery.
- **Step 2:** Press the ON/OFF switch on the side of the inverter. The screen and indicator lights turning on indicates that the inverter has been activated.
- **Step 3:** Sequential close of the circuit breakers for PV, AC input and AC output.
- **Step 4:** Start the loads one by one in order of power from small to large.

4.9 Parallel Connection

4.9.1 Introduction to Parallel Connection

1. Up to 9 units connected in parallel.
2. When using the parallel operation function, the following connecting lines (package accessories) shall be firmly and reliably connected.

Parallel Communication Cable * 1

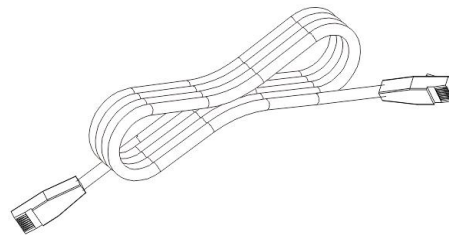

4.9.2 Precautions for Parallel Connection Cables

1.PV connection:

When connecting in parallel, the PV arrays connected to each inverter must be independent of each other. The PV arrays corresponding to PV1, PV2, and PV3 ports of the same inverter must also be independent.

2.Battery connection:

For single-phase or three-phase parallel operations, all solar energy storage inverters must be connected to the same battery bank. Connect BAT+ to BAT+ and BAT- to BAT-. Before powering on the system, thoroughly check the wiring configuration to ensure correctness. Confirm that the wiring lengths between each inverter and the battery are consistent, and verify that the cable size meets the system's current transmission requirements. Incorrect connections may cause abnormal operation of the parallel system.

3.Load connection:

In three-phase parallel connections, all solar energy storage inverters must be connected with N to N and PE to PE. The AC output L lines of the same phase should be connected together. The wiring method is the same when using a generator as a Smart load.

4.Grid connection:

In three-phase parallel connections, all solar energy storage inverters must be connected with N to N and PE to PE. The grid L lines of the same phase should be connected together. The wiring method is identical when using a generator as an input source or for micro-inverters.

5.Communication Lines:

Our parallel communication cable is a shielded 8-pin network cable suitable for both single-phase and three-phase parallel connections. Each unit must have one input and one output connection. In a parallel system, the "Parallel A" interface of this machine must be connected to the "Parallel B" interface of the target machine. It is strictly prohibited to connect the "Parallel A" interface of this machine to either the "Parallel B" interface of the same machine or the "Parallel A" interface of the target machine. Additionally, secure each unit's parallel communication cable firmly to the 8-pin network connector to prevent disconnections or poor contacts, which may lead to abnormal system operation or damage to the output.

6. Before and after connecting the system, carefully refer to the system wiring diagram below. Ensure all connections are correct and secure before powering on.

7. After the system is correctly wired, powered on, and operating normally, if a new inverter needs to be connected, ensure that the battery input, PV input, AC input, and AC output are disconnected, and all solar energy storage inverters are powered off before reconnecting to the system.

4.9.3 Schematic of Three-Phase Parallel Operation

Set the parallel mode of each inverter to "Parallel".

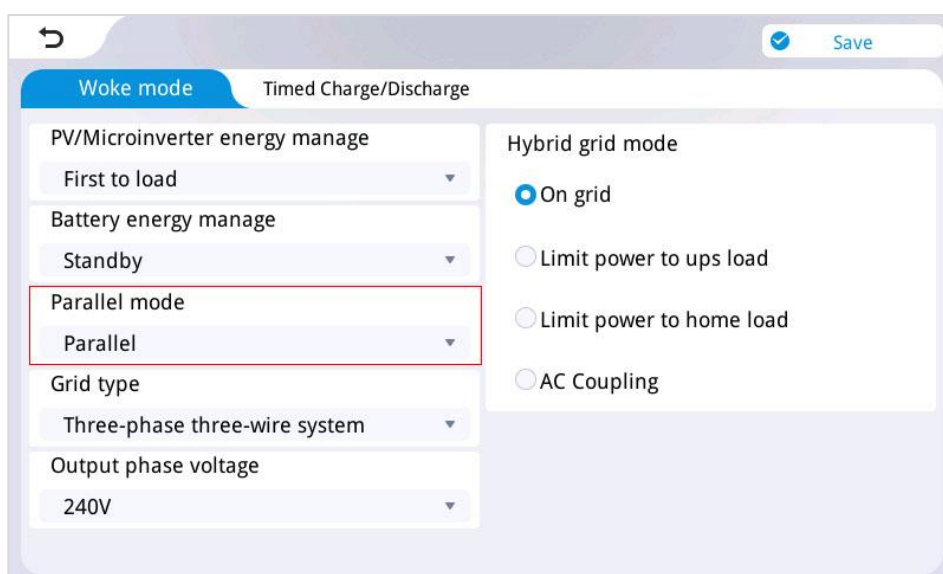

a) Two units connected in parallel:

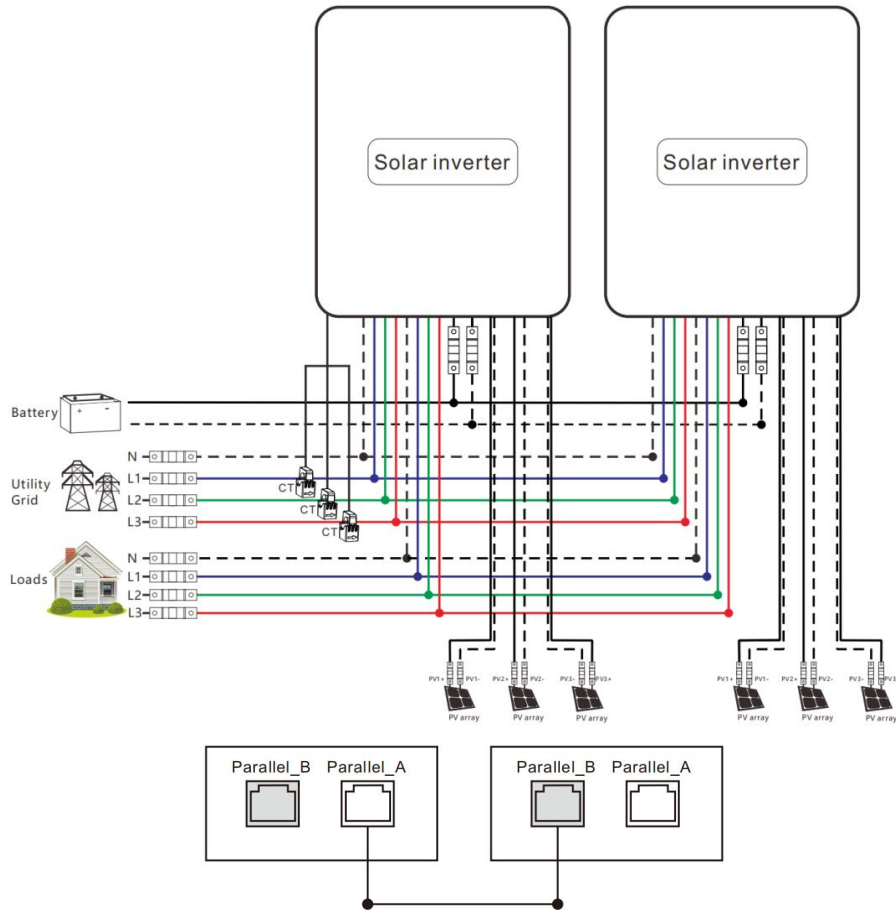

b) Three units connected in parallel:

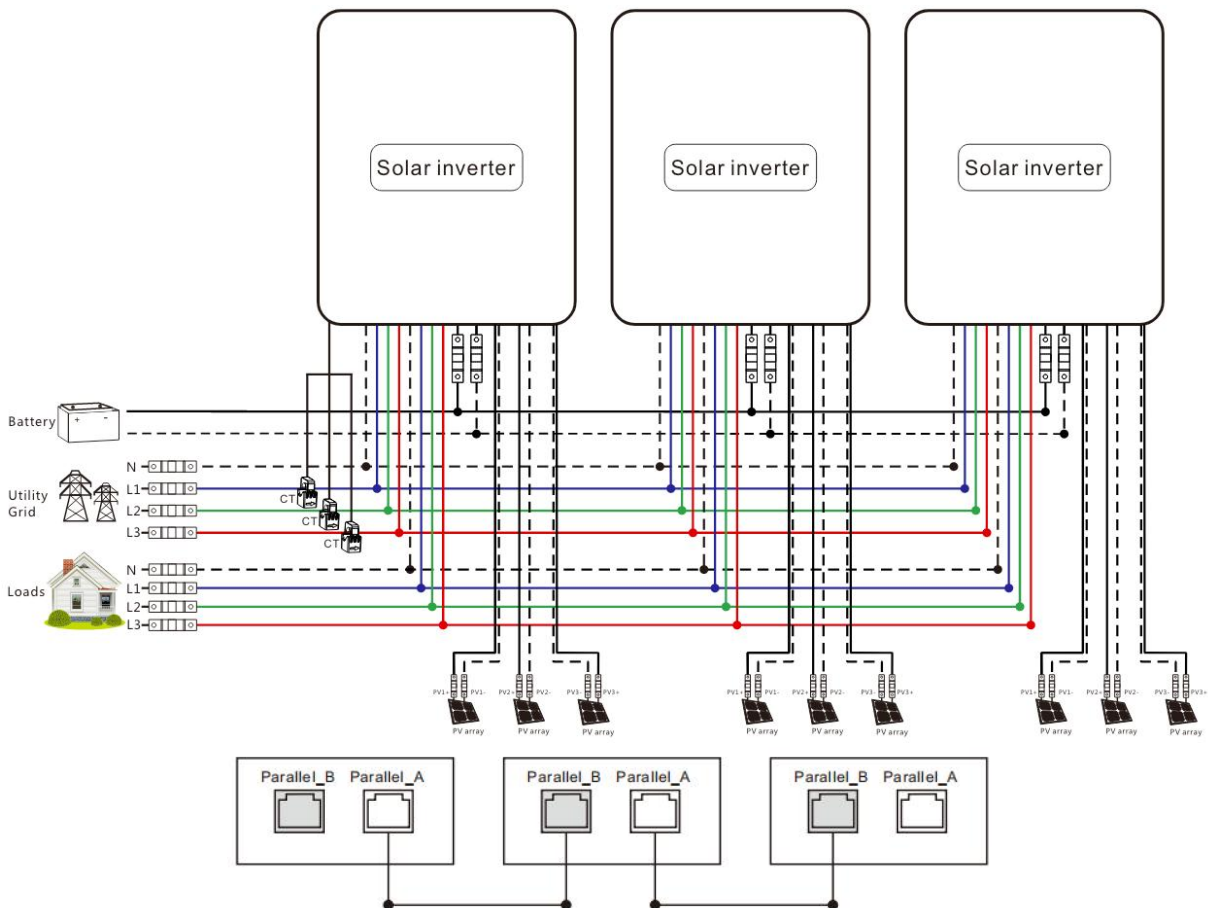

c) Four units connected in parallel:

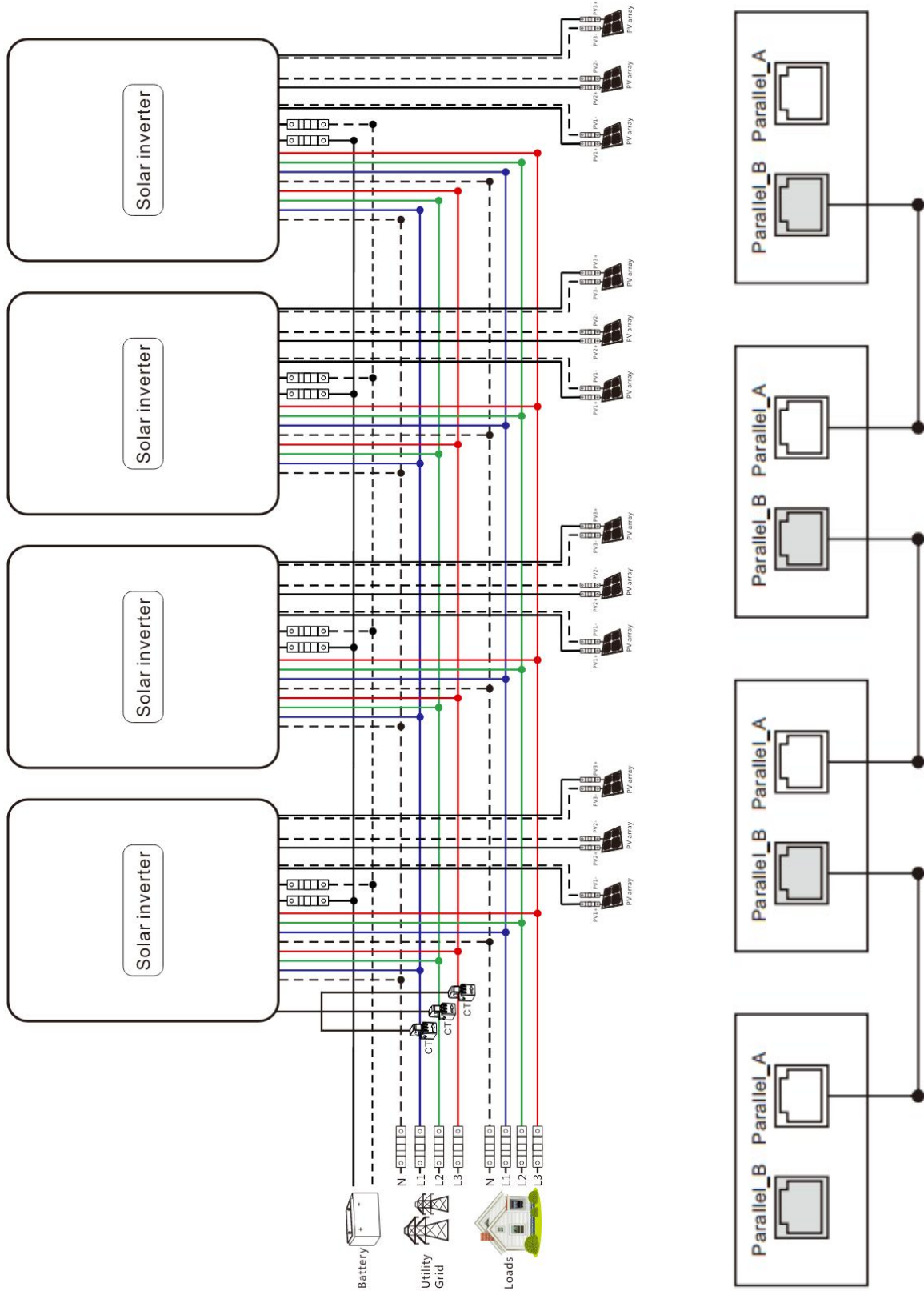

d) Five units connected in parallel:

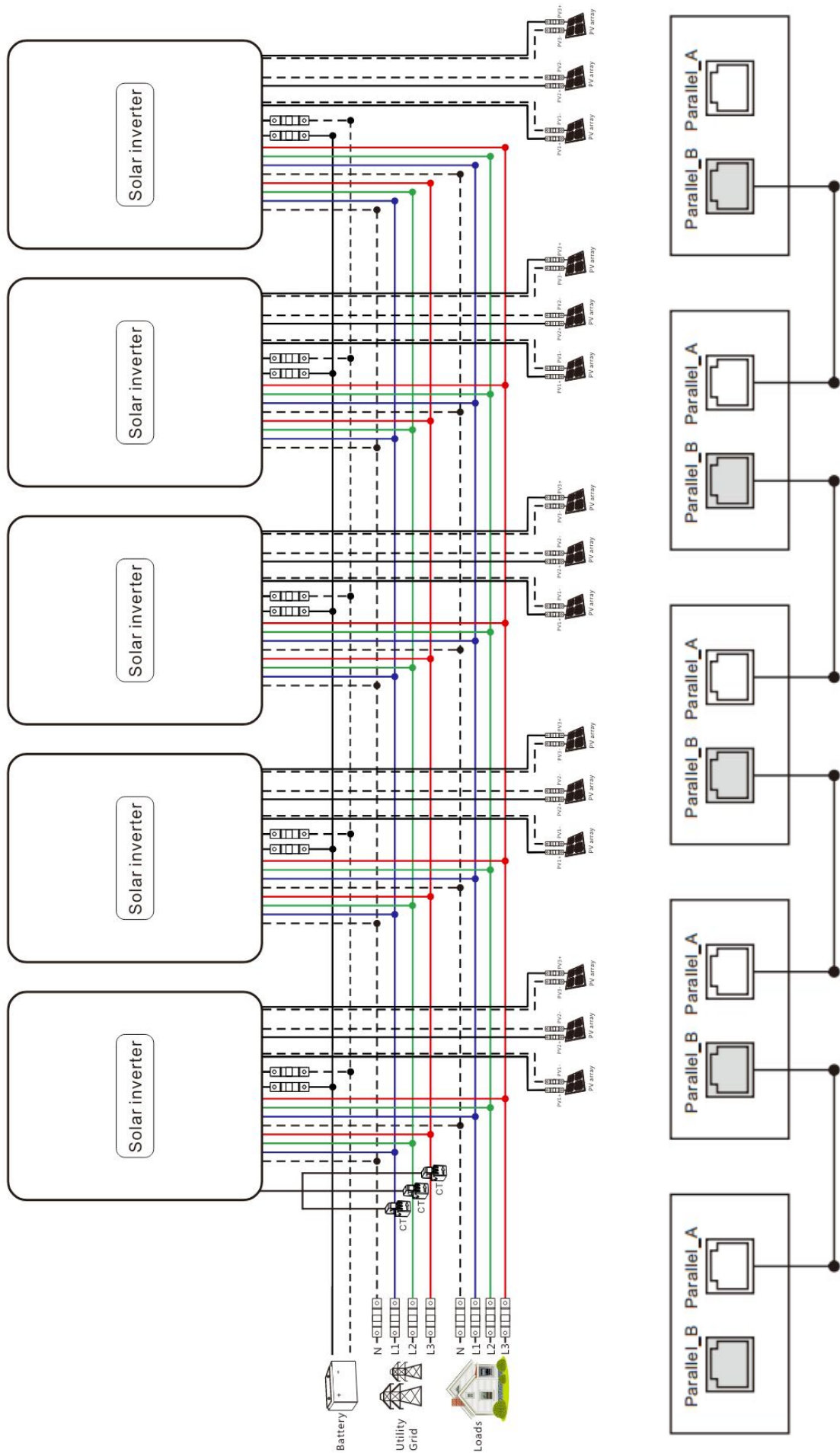

e) Six units connected in parallel:

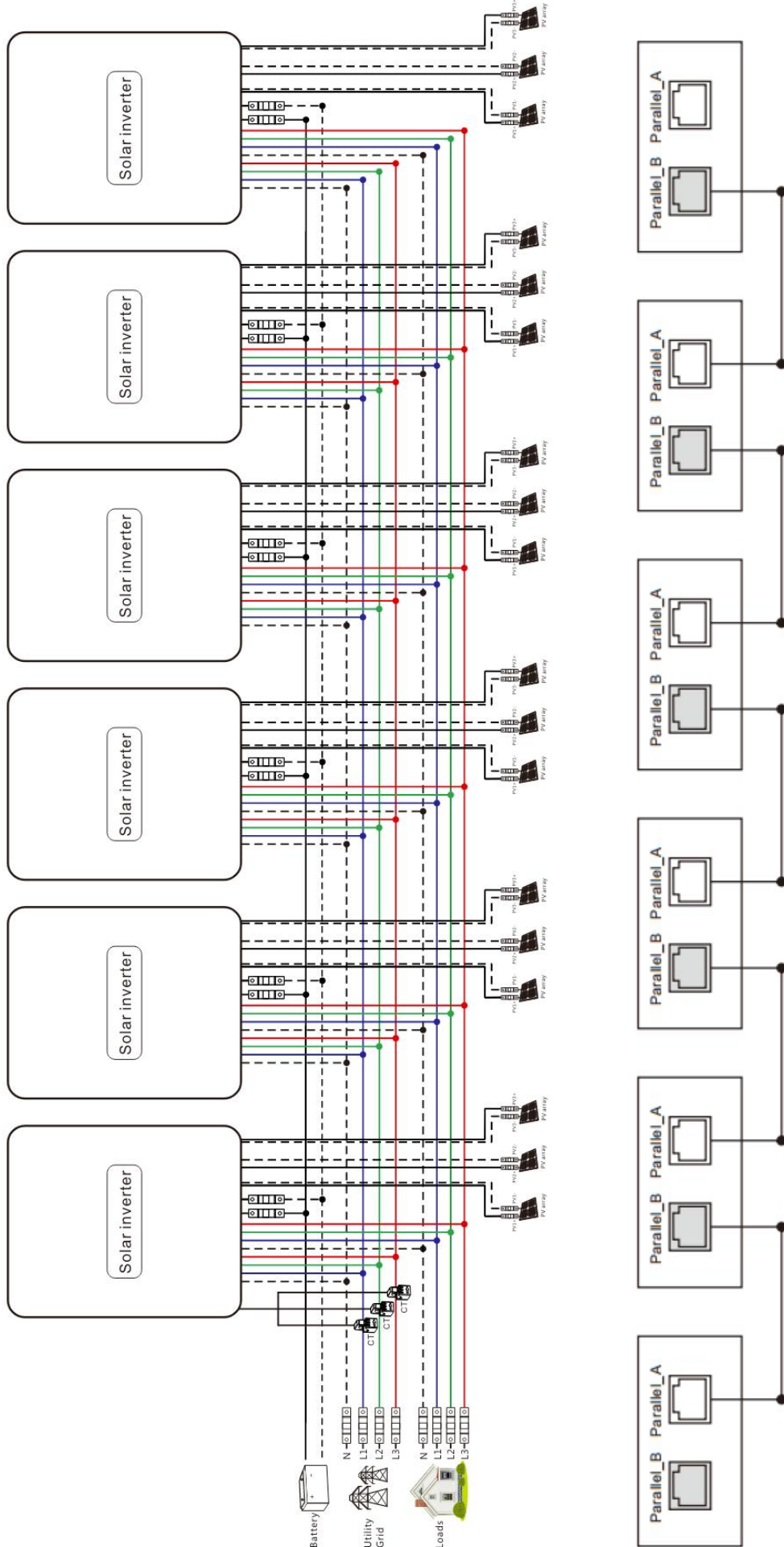



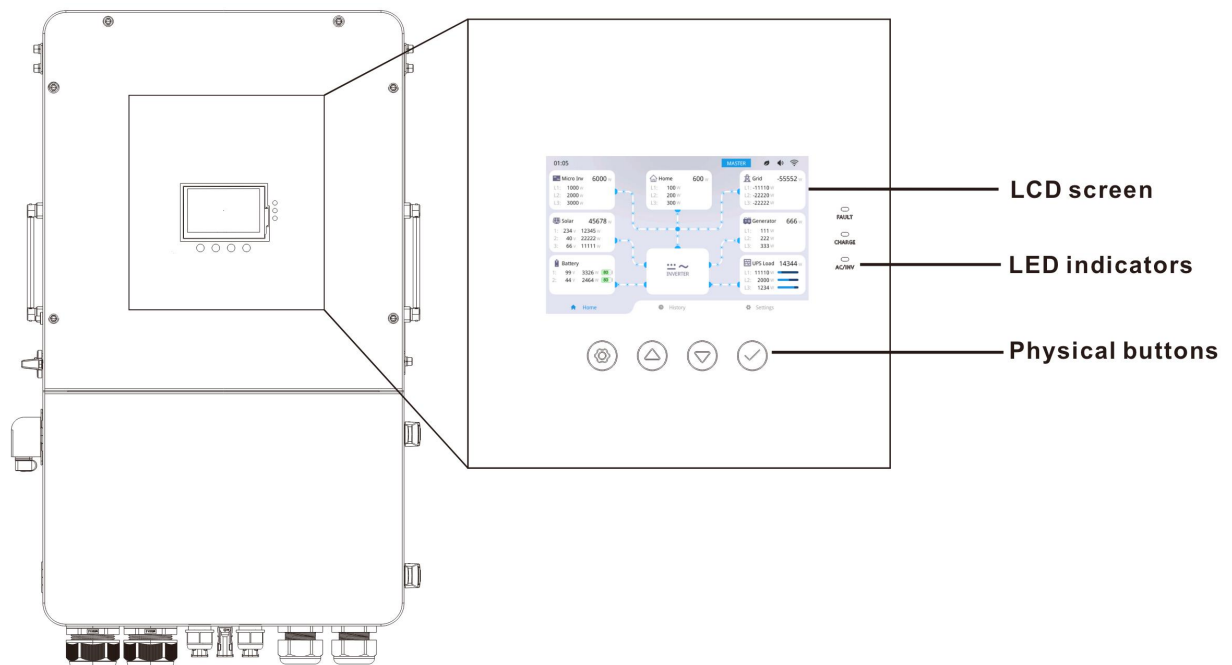

5. Operation

5.1 Operation and Display Panel

The operation and display panel consists of one (1) LCD screen, three (3) LED indicators, and four (4) operation buttons, as shown below.



■ Operation buttons

Button	Description
	To enter/exit the setting menu
	To last selection
	To next selection
	To confirm/enter the selection in setting menu

■ LED indicators

Indicator	Color	Description
FAULT	Red	Flashing: Error occurred
CHARGE	Green	Continued: Charging completed
		Flashing: Charging in progress
AC/INV	Yellow	Continued: Utility grid bypass output
		Flashing: Inverter output

■ Display Panel

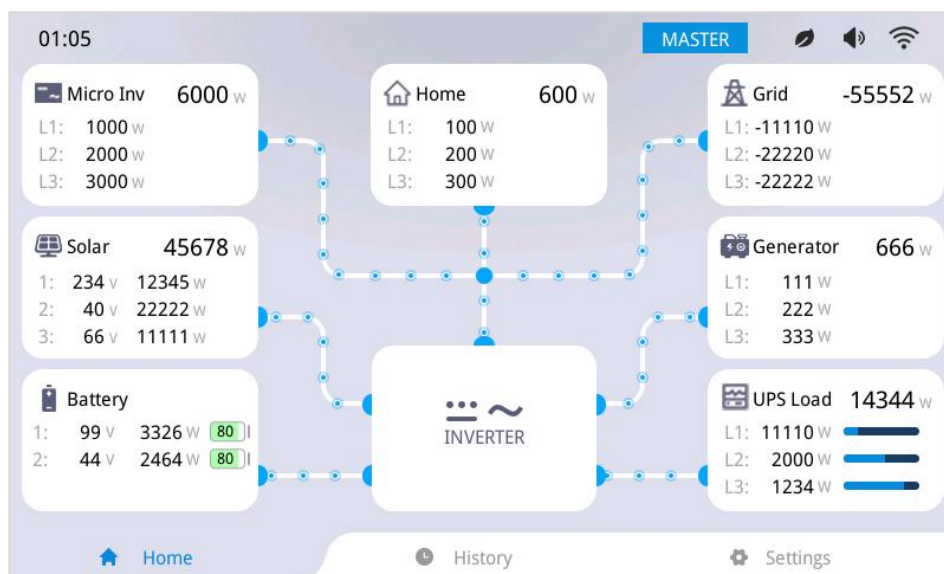

Icon	Description	Icon	Description
	Microinverter		Grid
	Solar Panel		Generator
	Battery		UPS Load
	Household Load		Inverter
	Home Page		Energy Saving Mode
	Historical Data		Settings
01 : 05	Local Time		Buzzer
	WiFi Status		Energy Flow
MASTER	Main Unit Logo		

■ View real-time data

On the LCD home screen, click the inverter icon, battery icon, utility grid icon, generator icon, UPS load icon, or PV icon allows viewing of real-time data for each component. The microinverter and household load icons are non-clickable, as their data is fully displayed on the home page.

System Data			
NO.	Real-Time Data Item	NO.	Real-Time Data Item
1	Main DSP MCU1 Version	11	SN Code (Inverter Serial Number)
2	Main DSP MCU2 Version	12	Machine Status
3	Minor Version Number	13	DC/DC Temperature
4	Auxiliary DSP Version	14	DC/AC Temperature

5	Rated Power	15	Transformer Temperature
6	Customer ID	16	Inductor Temperature
7	RS485 Address	17	Parallel Total Local Load Power
8	Bus Positive Voltage	18	Parallel Total Household Load Power
9	Bus Negative Voltage	19	Parallel Total Grid Power
10	Bus Total Voltage	20	Parallel Total Generator Power
Battery Data			
1	Battery 1 Voltage	7	Battery 2 Voltage
2	Battery 1 Charge/Discharge Power	8	Battery 2 Charge/Discharge Power
3	Battery 1 Charge/Discharge Current	9	Battery 2 Charge/Discharge Current
4	Battery 1 SOC (%)	10	Battery 2 SOC (%)
5	Battery Type	11	BMS Communication Protocol
6	Charging Status	12	BMS Data
Utility Data			
1	L1 Voltage	8	L2 Voltage
2	L1 Current	9	L2 Current
3	L1 Active Power	10	L2 Active Power
4	L1 Apparent Power	11	L2 Apparent Power
5	L3 Voltage	12	L3 Active Power
6	L3 Current	13	L3 Apparent Power
7	Frequency	14	Utility Charging Current
UPS Load Data			
1	L1 Voltage	10	L2 Voltage
2	L1 Current	11	L2 Current
3	L1 Active Power	12	L2 Active Power
4	L1 Apparent Power	13	L2 Apparent Power
5	L3 Voltage	14	L3 Apparent Power
6	L3 Current	15	L3 Active Power
7	L1 Load Rate	16	L2 Load Rate
8	L3 Load Rate	17	Frequency
9	Overall Load Rate		
PV Panel Data			
1	Solar1 Voltage V	6	Solar2 Power W
2	Solar1 Current A	7	Solar3 Voltage V
3	Solar1 Power W	8	Solar3 Current A
4	Solar2 Voltage V	9	Solar3 Power W
5	Solar2 Current A	10	PV Total Power

Generator Data			
1	L1 Voltage	8	L2 Voltage
2	L1 Current	9	L2 Current
3	L1 Active Power	10	L2 Active Power
4	L1 Apparent Power	11	L2 Apparent Power
5	L3 Voltage	12	L3 Active Power
6	L3 Current	13	L3 Apparent Power
7	Frequency	14	Charging Current
Smart Load Data			
1	L1 Current	6	L2 Current
2	L1 Active Power	7	L2 Active Power
3	L1 Apparent Power	8	L2 Apparent Power
4	L3 Current	9	L3 Apparent Power
5	L3 Active Power	10	Total Load Power

■ Browsing Detailed Data with Buttons

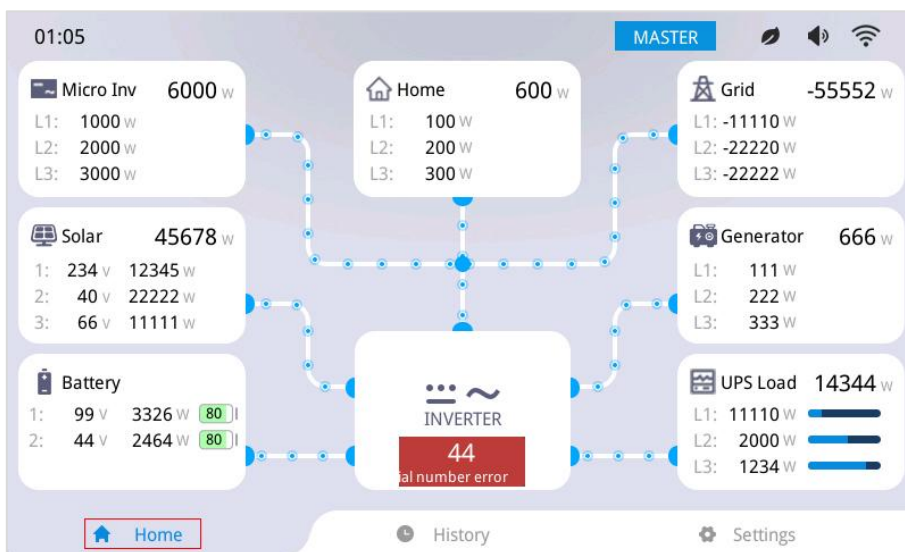

1. Press the up/down buttons, and when "HOME" is highlighted in blue, press the confirm button to select the home page icon.



2. After selecting the home page icon, press the confirm button again to enter the data details page.

5.2 Setting Parameters

Operation Instructions:

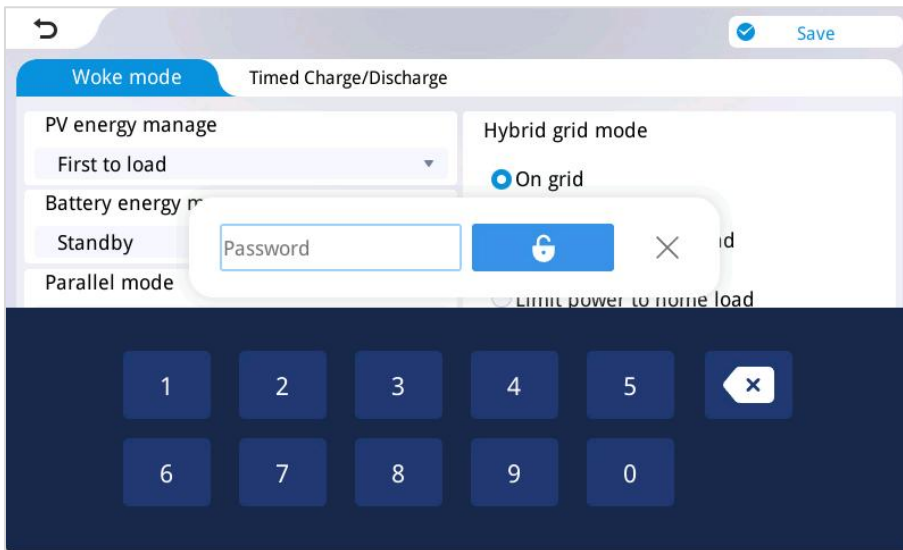

1. Click the "Settings" button in the bottom menu bar of the screen to enter the settings interface. It includes seven categories: "Basic setup", "Work mode setup", "Battery setup", "On-grid setup", "Advance setup", "WiFi setup", and "Firmware Upgrade".

2. When modifying settings, if password protection is enabled, you must enter the password to change parameters. The default password is "4321".

Setting Flow Chart:

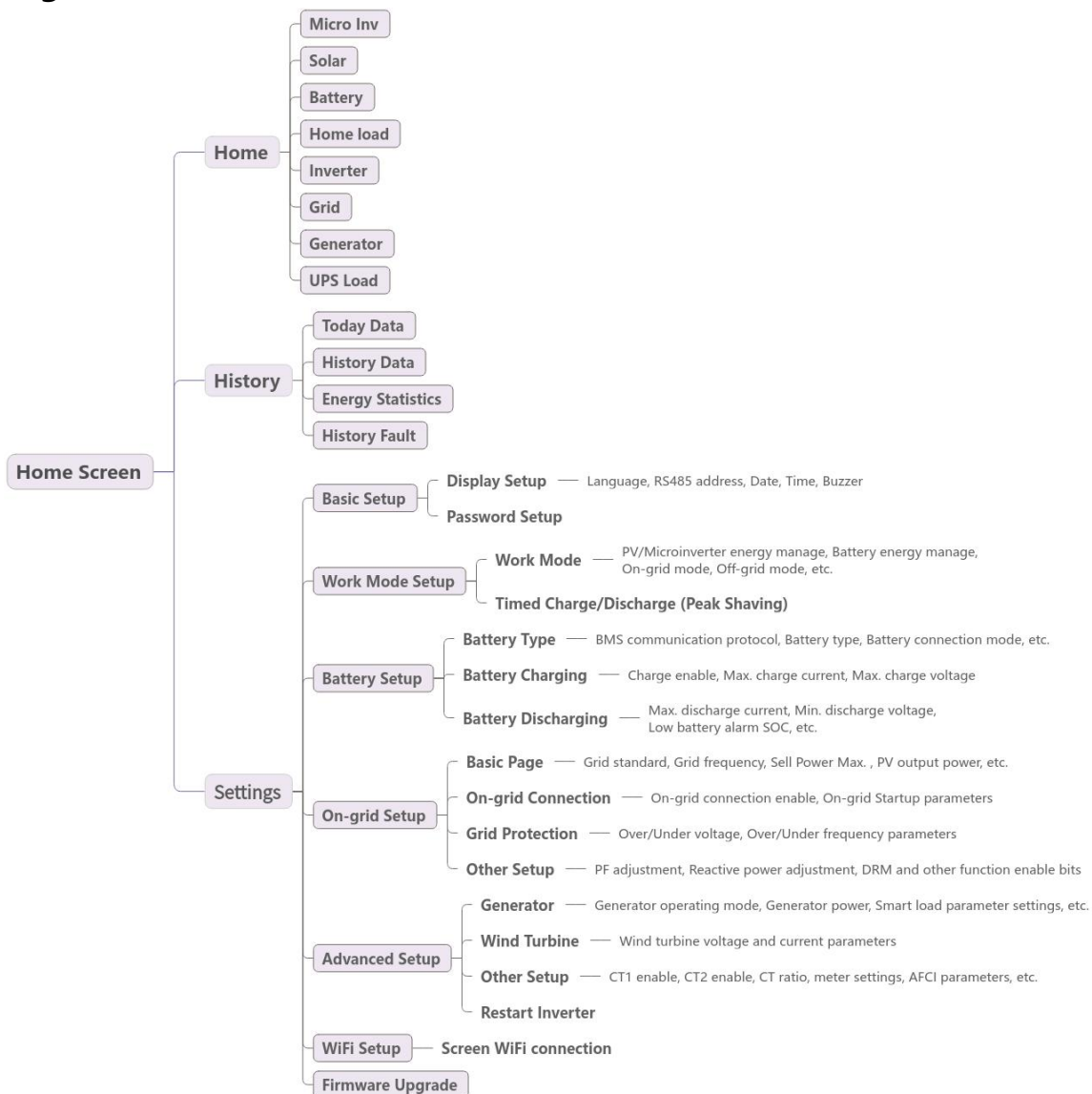

5.2.1 Basic Setup

5.2.1.1 Display Setup

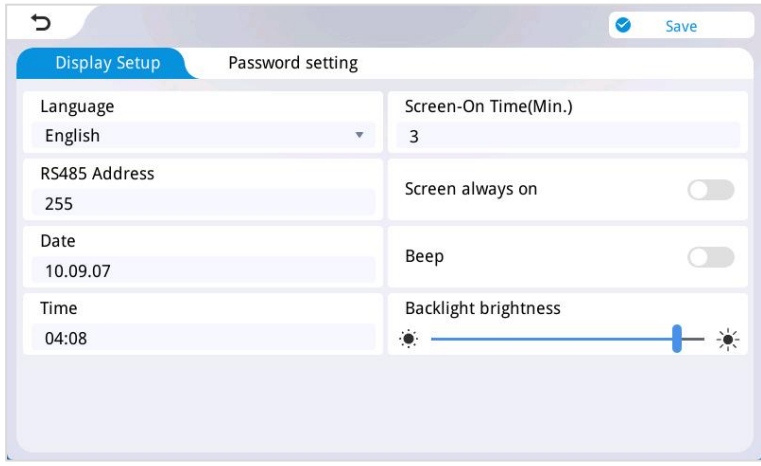

- **Language:** English, Italian, German, Spanish, Chinese.
- **RS485 Address:** RS485 address of the inverter.
 - ① Single device: Adjustable range 1~254.
 - ② Parallel devices: Adjustable range 1~9.
- **Date:** Set year, month, day.
- **Time:** Set hour and minute.
- **Screen-On Time(Min.):** Adjustable range 1~30 minutes.
- **Screen always On:** Select whether the screen stays on continuously.

- **Beep:** Select whether to enable buzzer alarm.
- **Backlight brightness:** Adjustable from 0~100%.

5.2.1.2 Password Setup(Change Password)

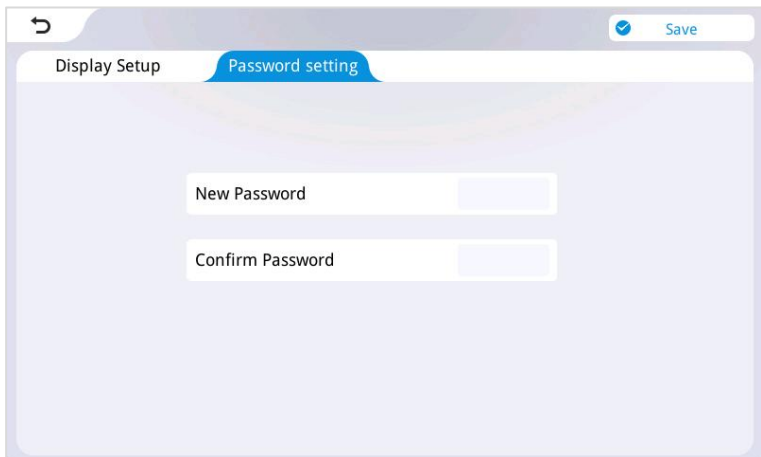

- **New Password:** Enter a custom new password.
- **Confirm Password:** Re-enter exactly the same content as the new password above to verify the accuracy of the password setting.

5.2.2 Work Mode Setup

5.2.2.1 Work Mode

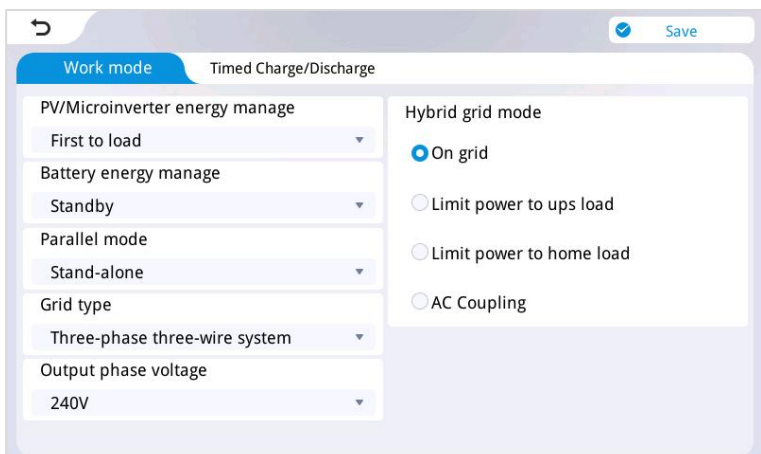

- 1. UPS Load:** Connected to the LOAD port of the machine.
- 2. Smart Load:** Refers to the load connected to the machine's GEN port.(Only valid when the GEN port is set to the smart load function.)
- 3. Home Load:** Refers to the load connected to the machine's GRID port, which requires external CT or energy meter for use.(Otherwise, the power of the Home load cannot be detected.)

This is the detailed page of "Work Mode"		
Parameter Meaning	Options	Description
Hybrid grid mode	On grid	Direct grid connection of excess PV energy.
	Limit power to UPS load	In this mode, solar or battery energy is only used for UPS load and smart load, Excess energy will not be fed into the grid (UPS load is reverse-flow protected).
	Limit power to home load	In this mode, solar or battery energy is used only for the UPS load, smart load, and home load. Excess energy will not be fed into the grid (HOME load is reverse-flow protected).
	AC Coupling	This mode is used to add AC coupling functionality to on-grid inverters. The on-grid inverter needs to be connected to the grid side of the hybrid inverter (effective only when the GEN port is not set to micro-inverter mode); or connected to the generator side of the hybrid inverter (effective only when the GEN port is set to micro-inverter mode). In this mode, the hybrid inverter will use the grid energy from the on-grid inverter to power loads or charge batteries.
PV/Microinverter energy manage	When the hybrid grid mode is set to "Limit power supply to UPS load" or when CT1 is not connected, the meter is not communicating, or communication fails (effective only when the meter detection location is set to the grid side), the subsequent loads refer to the UPS load and smart load. When the hybrid grid mode is set to "Limit Home Load/Grid Power Supply" and CT1 is successfully connected or the meter communication is successful (effective only when the meter detection location is set to the grid side), the subsequent loads refer to the UPS load, smart load, and home load.	
	First to Load	PV energy priority: load>charge>on grid. Micro-inverter energy priority: load>charge>on grid.
	First to charging	PV energy priority: charge>load>on grid. Micro-inverter energy priority: load>charge>on grid.
	First to grid	PV energy priority: load>on grid>charge. Micro-inverter energy priority: load>on grid>charge.
Battery energy manage	Standby	Battery only discharge in off-grid working mode.
	Battery to UPS load	The battery can supply power to the UPS load, smart load, and home load, but does not participate in selling power to the grid.
	Battery to home load	The battery powers UPS loads, smart loads, and household loads, but does not participate in grid selling.
	Battery to grid sell	The battery can supply power to the UPS load, smart load, and home load, and participate in selling power to the grid.
Parallel mode	Stand-alone.	
	Parallel operation.	
Grid type	Three-Phase Three-Wire System.	
	Three-Phase Four-Wire System.	
Output phase voltage	Settable: 200V,208V,220V,230V,240V	

5.2.2.2 Timed Charge/Discharge

Work mode: Timed Charge/Discharge

Timed charging enable

	Start Time	End Time	Stop SOC	Stop Volt	Max Power	Grid	Gen
1	01:01	02:02	1%	55.0V	444W	<input checked="" type="checkbox"/>	<input checked="" type="checkbox"/>
2	03:03	04:04	2%	22.0V	555W	<input type="checkbox"/>	<input type="checkbox"/>
3	05:05	06:06	3%	33.0V	666W	<input type="checkbox"/>	<input type="checkbox"/>

Timed discharging enable

Max consumption enable

	Start Time	End Time	Stop SOC	Stop Volt	Max Power
1	07:07	08:08	4%	44.0V	111W
2	09:09	10:10	6%	55.0V	222W
3	11:11	12:12	7%	66.0V	333W

Work mode: Timed Charge/Discharge

Monday enable	<input checked="" type="checkbox"/>	Tuesday enable	<input type="checkbox"/>
Wednesday enable	<input checked="" type="checkbox"/>	Thursday enable	<input type="checkbox"/>
Friday enable	<input type="checkbox"/>	Saturday enable	<input checked="" type="checkbox"/>
Sunday enable	<input checked="" type="checkbox"/>		

- **Timed charging enable:** Select whether to enable scheduled charging.
- **Timed discharging enable:** Select whether to enable scheduled discharging.
- **Start/End Time:** Set the time period for scheduled charging/discharging.
- **Stop SOC:** Set the battery's cutoff SOC values for charging/discharging during the scheduled charging/discharging time periods. (effective when BMS communication is successful).
- **Stop Volt:** Set the battery's cutoff voltage values for charging /discharging during the scheduled charging/ discharging time periods. (effective when BMS communication is not established or fails).
- **Max. Power:** Setting the battery charging power and discharging power during the scheduled charging and discharging time period.
- **Grid:** Allow the grid to charge the battery during the scheduled charging period.
- **Gen:** Allow the generator to charge the battery during the scheduled charging period.

- **Max. consumption enable:** Allow the battery to discharge outside the scheduled discharging period.
- **Weekly Enable:** Set the days of the week for scheduled charging/discharging (only valid for scheduled charging/discharging).

5.2.3 Battery Setup

5.2.3.1 Battery Type

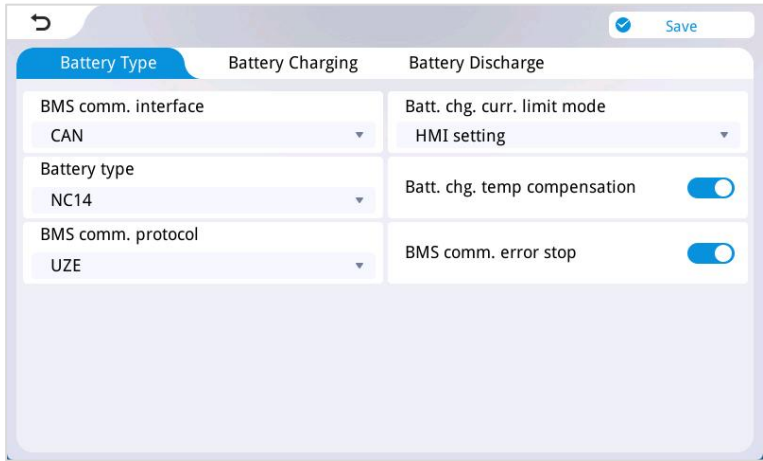

- **BMS comm. interface:**

- ① **Disable:** BMS communication disabled.
- ② **RS485:** BMS RS485 communication.
- ③ **CAN:** BMS CAN communication.

- **Battery Type:**

- ① **USER define:** All battery parameters can be customized by the user.
- ② **SLd:** Sealed Lead-acid Battery.
- ③ **FLd:** Flooded Lead-acid Battery.
- ④ **GEL:** Gel Lead-acid Battery.
- ⑤ **No battery:** No battery connected.

⑥ **LFP/14/ 15/LFP 16:** Li-FePO₄ /14/15/16, corresponding to 14-series, 15-series, and 16-series Li-FePO₄ batteries.

⑦ **N13/ N14:** NCM Lithium Battery N13/N14, corresponding to 13-series and 14-series NCM lithium batteries.

- **BMS comm. protocol:** When the BMS port selection item is set to RS485 or CAN, the corresponding lithium battery manufacturer brand shall be selected for communication:

- ① **485 protocol:**

PACE=PACEEX	RUDA=RADAR	AOGUAN=AUTOONE	OULITE=OLITER	CEF=CFGE
XINWANGDA	XiongTao	DAQIN=Dyness	WOW=SRNE	PYL=Pylontech
MIT=FOX ESS	XIX=Xinyi energy	POL=PowMr	GUOX=GOTION	SMK=SMK POWER
VOL=VILION	WES	SGP	GSL	PYT=Pylon tech 2

- ② **CAN protocol:**

UZE=UZENERGY	PYL=Pylontech	Victro	DEY	HONGHE
WOW=SRNE	SGP=SGP	GSL=GSL energy	PYL=Pylontech	RUIXU
RENAC	DUNEXT	General	LUX/LuxPower	

Note: Please refer to the actual display on the screen.

- **Battery chg. curr. limit mode(valid for BMS communication):**

- ① **HMI setting:** The maximum battery charging current is limited by the charging current setting value of the inverter.
- ② **BMS setting:** The maximum battery charging current is restricted by the current limit value of the BMS.
- ③ **Inverter setting:** The maximum battery charging current is limited by the derating logic of the device.

- **Batt. Chg Temp Compensation:** Used to select whether to enable temperature compensation.

5.2.3.2 Battery Charging

Battery Type	Battery Charging	Battery Discharge
Grid charging enable	<input checked="" type="checkbox"/>	Max. chg. curr. by Grid 2.2A
Generator charging enable	<input checked="" type="checkbox"/>	Max. chg. curr. by gen. 333.0A
Max. chg. voltage	9.5V	Max. chg. current 1.1A
Batt. Recharging voltage	15.0V	Batt. curr. stop chg. 5.5A
Batt. SOC stop chg.	88%	

- **Grid charging enable:** Select whether to allow the grid to charge the battery (not applicable to scheduled charging).
- **Generator charging enable:** Select whether to allow the generator to charge the battery (not applicable to timed charging).
- **Max. chg. voltage:** Set the maximum charging voltage during constant voltage charging of the battery.

- **Batt. Recharging voltage:** After the battery is fully charged, the inverter stops charging. Charging resumes when the battery voltage drops below this value. (This setting is effective when BMS communication is not established or has failed.)
- **Batt. SOC stop chg.:** When the SOC reaches the specified value, battery stops charging. (Valid when BMS communication is normal).
- **Max. chg. curr. by Grid:** Set the maximum charging current from the grid to the battery. (Note: This value refers to the battery-side current, not the grid-side current, and does not apply to scheduled charging.)
- **Max. chg. curr. by gen.:** Set the maximum charging current from the generator to the battery. (Note: This value refers to the battery-side current, not the generator-side current, and does not apply to scheduled charging.)
- **Max. chg. current:** Set the maximum charging current during the constant current phase of battery charging.
- **Batt. curr. stop chg.:** During the constant voltage charging phase, charging will cease when the charging current falls below this value. (Effective when BMS communication is not performed or BMS communication fails).

Note: After the battery is fully charged, the inverter stops charging. Charging will resume when the battery SOC drops below this value. (Fixed at Battery Charging Stop SOC - 5%, non-modifiable, effective when BMS communication is normal)

5.2.3.3 Battery Discharging

Battery Type	Battery Charging	Battery Discharge
Batt. volt. stop dischg. in hybrid	9.0V	Batt. SOC stop dischg. in hybrid 11%
Batt. volt. restart dischg.	10.0V	Batt. SOC restart dischg. 55%
Batt. under volt. alarm	20.0V	Batt. under capacity alarm 33%
Batt. volt. low recovery	12.1V	Batt. SOC low fault 44%
Batt. voltage low fault	22.2V	Batt. volt. low delay 2570S
Batt. max. curr. dischg.	5.5A	

- **Batt. under volt. alarm:** When the battery voltage is lower than this value, the inverter will report an under-voltage alarm (notifying the user that the battery is about to stop discharging), but the battery will not stop discharging. (Effective when BMS communication is not established or fails.)
- **Batt. under capacity alarm:** SOC value up to this setting will alarm. The inverter output will not shut down and the fault disappears if the SOC value exceeds 5% of the set value. (Valid when BMS communication is normal)

- **Batt. volt low recovery:** When the battery report voltage low fault, the battery voltage reach this setting, the fault will be cleared.
- **Batt. SOC low fault:** When the battery SOC is lower than this value, the inverter will report a low battery SOC fault and stop discharging. (Effective when BMS communication is normal.)
- **Batt. voltage low fault:** When the battery voltage is lower than this value and after the "Discharge Stop Delay Time" elapses, the inverter will report a low battery voltage fault and stop discharging.
- **Batt. volt. low delay:** Battery stop discharge delay time.
- **Batt. max. curr. dischg.:** Set the max. battery discharger current.

The following settings are only effective in hybrid grid operation mode:

- **Batt. volt. stop dischg. in hybrid:** Discharging stops when the battery voltage is lower than this value. (Effective when BMS communication is not established or fails.)
- **Batt. SOC stop dischg. in hybrid:** Discharging stops when the battery SOC is lower than this value. (Effective when BMS communication is normal.)
- **Batt. volt. restart dischg. :** The inverter stops discharging after low battery voltage, and resumes discharging when the battery voltage rises above this value. (Effective when BMS communication is not established or fails.)
- **Batt. SOC restart dischg.:** The inverter stops discharging after low battery capacity, and resumes discharging when the battery SOC rises above this value. (Effective when BMS communication is normal.)

5.2.4 Grid Connection Setup

5.2.4.1 Basic Page

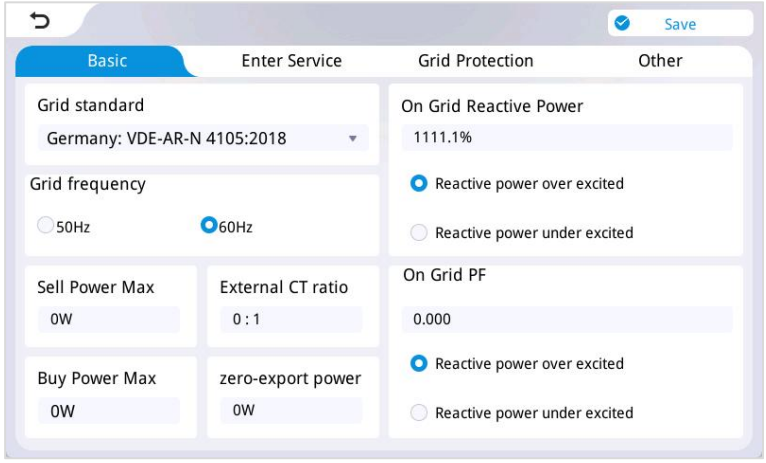

- **Grid frequency:** Select the local grid frequency (50Hz/60Hz).
- **Sell Power Max:** Set the maximum power for feeding into the grid.
- **Buy Power Max:** Maximum power drawn from the grid. If the grid charging power + load power by the grid exceeds this setting, the inverter will prioritize reducing the grid charging power to avoid exceeding the buying power threshold.

- **External CT ratio:** When connecting an external CT, enter the ratio on the CT specification. (CT is fixed for grid-side power collection.)
- **zero-export power:** Error calibration power for anti-backflow, recommended to be set between 20-100W. Due to sampling accuracy issues, in order to bring the anti-backflow side power close to 0W:
 - ① When buying power $P > 0$, set this value to P ;
 - ② When selling power $P > 0$, set this value to $-P$.
- **On Grid Reactive Power:** Setting range 0-100%, expressed as a percentage of reactive power.
- **Reactive power over/under excited:** "over" indicates 0%-100% / "under" indicates -100% ~ 0%.
- **On Grid PF:** Setting range 0.8 ~ 1.
- **Reactive power over / under excited:** "over" indicates 0.8 ~ 1 / "under" indicates -0.8 ~ -1

● **Grid standard (subject to the actual display on the screen.):**

Austria: TE-OVE	Thailand: PEA-MEA PEA-MEA	Italy: CEI 0-21:2022/V1:2022
Germany: VDE-AR-N 4105:2018	Europe: EN 50549-1	Spain: UNE 217002: 2020-10
United States: IEEE Std 1547	2018/IEEE1547	Great Britain: G99
South Africa: NRS097	Australia: AS4777.2 Australia A	Myanmar;
Poland: EN 50549-1	Australia: AS4777.2 New Zealand	Thailand: PEA-MEA
Ireland: EN50549-IE	United States: UL1741	Northern Ireland: G99/NI
Great Britain: G98	Puerto Rico	Uninitialized

5.2.4.2 Enter Service (User modification not recommended)

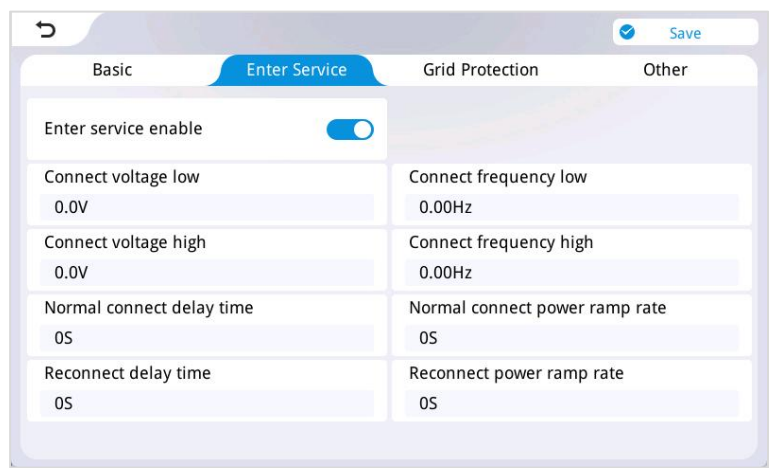

- **Enter service enable:** Grid connection startup setting (enabled by default).
- **Connect voltage low:** Minimum voltage requirement for grid connection.
- **Connect frequency low:** Minimum frequency requirement for grid connection.
- **Connect voltage high:** Maximum voltage requirement for grid connection.
- **Connect frequency high:** Maximum frequency requirement for grid connection.

- **Normal connect delay time:** The delay time for the inverter to connect to the grid when the grid first meets the connection requirements.
- **Normal connect power ramp rate:** The ramp rate of grid-connected power for the first grid connection.
- **Reconnect delay time:** Grid disconnection and reconnection, grid connection delay time.
- **Reconnect power ramp Rate:** Grid disconnection reconnection, rate of rise of grid-connected power.

5.2.4.3 Grid Protection (User modification not recommended)

Basic				Enter Service				Grid Protection				Other			
LV1	0.0V	Time	0ms	LF1	0.00Hz	Time	0ms	LV1	0.0V	Time	0ms	LF1	0.00Hz	Time	0ms
LV2	0.0V	Time	0ms	LF2	0.00Hz	Time	0ms	LV2	0.0V	Time	0ms	LF2	0.00Hz	Time	0ms
HV1	0.0V	Time	0ms	HF1	0.00Hz	Time	0ms	HV1	0.0V	Time	0ms	HF1	0.00Hz	Time	0ms
HV2	0.0V	Time	0ms	HF2	0.00Hz	Time	0ms	HV2	0.0V	Time	0ms	HF2	0.00Hz	Time	0ms

- **Time:** Time Protection Response Time.
- **LV1:** Class 1 undervoltage protection point. When the grid voltage drops below this threshold and remains so for the corresponding protection response time, the inverter shall disconnect from the grid.

- **LF1:** Class 1 underfrequency protection point. When the grid frequency drops below this threshold and remains below it for the corresponding protection response time, the inverter shall disconnect from the grid.
- **LV2:** Class 2 undervoltage protection point. When the grid voltage drops below this threshold and remains below it for the corresponding protection response time, the inverter shall initiate grid disconnection.
- **LF2:** Class 2 underfrequency protection point. When the grid frequency drops below this threshold and remains below it for the corresponding protection response time, the inverter shall disconnect from the grid.
- **HV1:** Class 1 overvoltage protection point. When the grid voltage rises above this threshold and remains above it for the corresponding protection response time, the inverter shall disconnect from the grid.
- **HF1:** Class 1 overfrequency protection point. When the grid frequency exceeds this threshold and remains above it for the corresponding protection response time, the inverter shall disconnect from the grid.
- **HV2:** Class 2 overvoltage protection point. When the grid voltage exceeds this threshold and persists above it for the preconfigured protection response time, the inverter shall initiate grid disconnection.
- **HF2:** Class 2 overfrequency protection point. When the grid frequency exceeds this threshold and remains above it for the specified protection response time, the inverter shall disconnect from the grid.

5.2.4.4 Other Page (User modification not recommended)

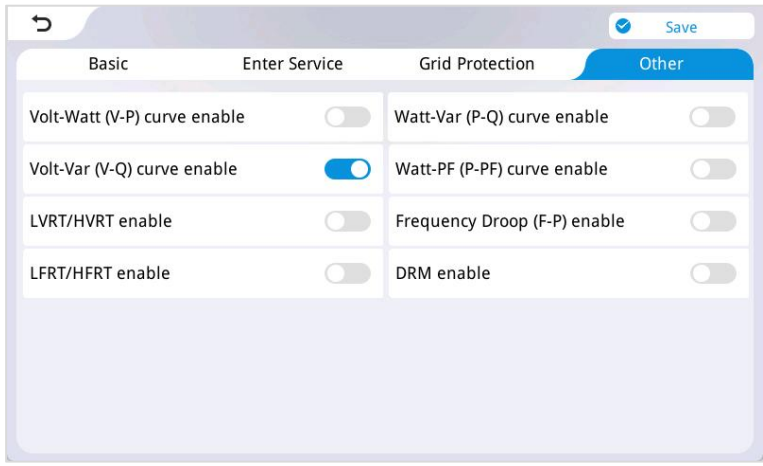

- **Volt-Watt (V-P) curve enable:** Regulates the active power of the inverter according to the set grid voltage.
- **Volt-Var (V-Q) curve enable:** Adjustment of the inverter reactive power according to the set grid voltage.
- **LVRT/HVRT enable:** Adjustment of the grid HV ride-through / LV ride-through values.

- **LFRT/HFRT enable:** According to the preset grid high-frequency/low-frequency ride-through thresholds.
- **Watt-Var (P-Q) curve enable:** Adjustment of the inverter reactive power according to the set active power.
- **Watt-PF (P-PF) curve enable:** Adjustment of the inverter power factor according to the set active power.
- **Frequency Droop (F-P) enable:** Adjustment of inverter output power according to grid frequency.
- **DRM Enable:** Australia only.

5.2.5 Advanced Setup

5.2.5.1 Generator

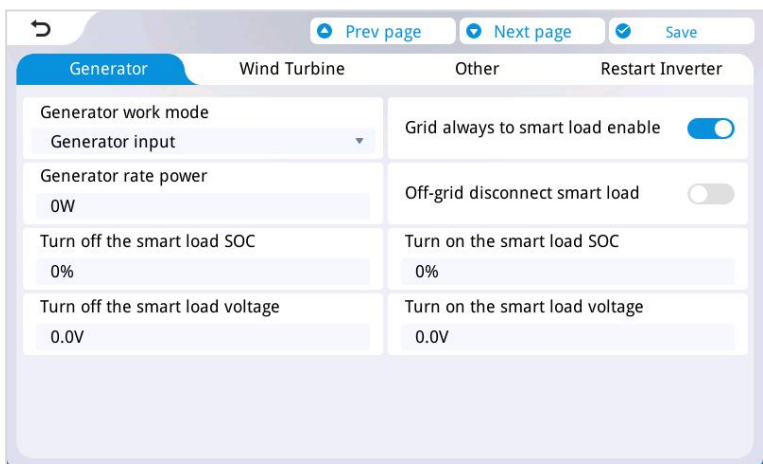

- **Generator work mode:**
 - ① **Generator input:** When the generator is connected to the "Gen port", select the "Generator input".
 - ② **Micro inverter input:** When the grid-tied inverter is connected to the "Gen Port" of the hybrid inverter, select the "Microinverter Input".
 - ③ **Smart load:** When the load is connected to the "Gen port", select "Smart load output".

- **Grid always to smart load enable:** When the inverter operates in hybrid grid mode, the smart load remains constantly enabled.
- **Generator rate power:** Setting the rated power of the generator.
- **Off-grid disconnect smart load:** When the inverter operates in off-grid mode, the smart load shall be immediately disabled.
- **Turn on the smart load SOC:** When battery SOC > this value, enable smart load. (Effective when BMS communication is normal)
- **Turn off the smart load SOC:** When battery SOC < this value, disable smart load. (Effective when BMS communication is normal).
- **Turn on the smart load voltage:** When battery voltage > this value, enable smart load. (Effective when BMS communication is not established or fails)

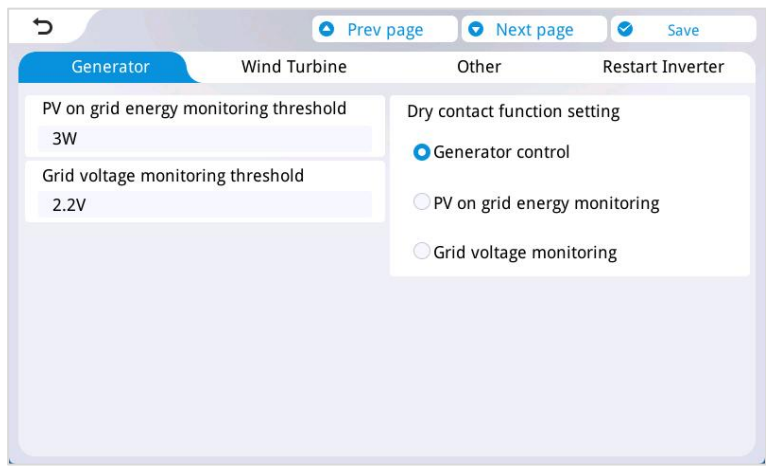

- **Turn off the smart load voltage:** When battery voltage < this value, disable smart load. (Effective when BMS communication is not established or fails).
- **Dry contact function setting:**
 - ① Generator control.
 - ② PV on grid energy monitoring.
 - ③ Grid voltage monitoring.
- **Grid voltage monitoring threshold:** When the grid voltage exceeds the threshold, the dry contact operates.

- **PV on grid energy monitoring threshold:** When the PV grid-connected energy exceeds the threshold, the dry contact operates.

5.2.5.2 Wind Turbine

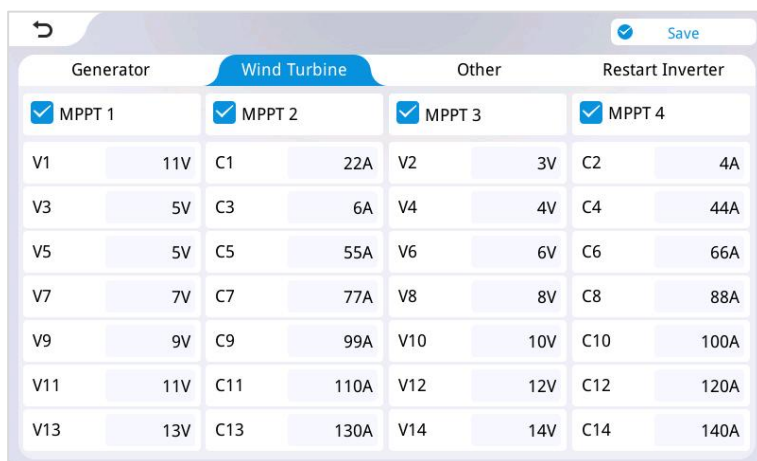

- **MPPT1/2/3/4:** Enable for wind turbine input.
- **V1/2/3/4.../14:** Voltage parameters for the wind turbine.
- **C1/2/3/4.../14:** Current parameters for the wind turbine.

5.2.5.3 Other Page

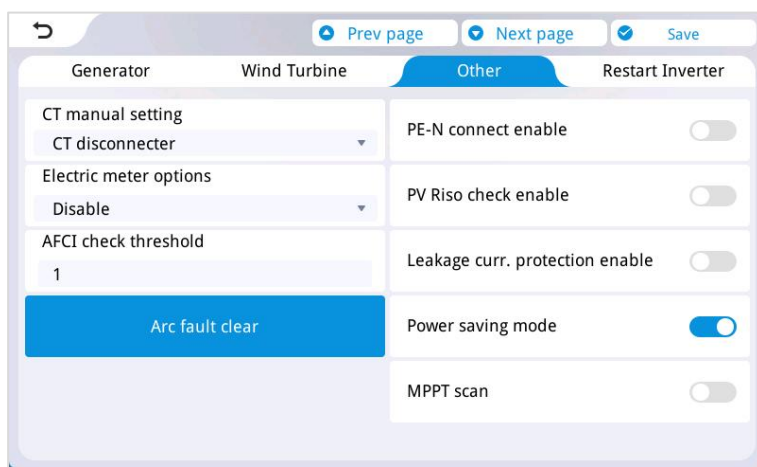

- **CT manual setting:** Select the CT direction based on the CT installation (ensure that the direction of each phase CT is consistent).
 - ① When the arrow on the CT points to the inverter, set it to "Point to Inverter".
 - ② When the arrow on the CT points to the grid, set it to "Point to Grid".
- **Electric meter options:** Whether to enable three-phase meter.
- **PE-N Connect enable:** Enable automatic switching of PE-N connections.

- **PV Riso check enable:** Enable PV insulation impedance detection.
- **Leakage curr. protection enable:** Enable leakage current protection.
- **Power saving mode:** When the energy-saving mode is activated:
 - ① If the load power is less than 35W, the inverter output will turn off after 5 min;
 - ② If the load power is greater than 56W, the inverter output will restart immediately.

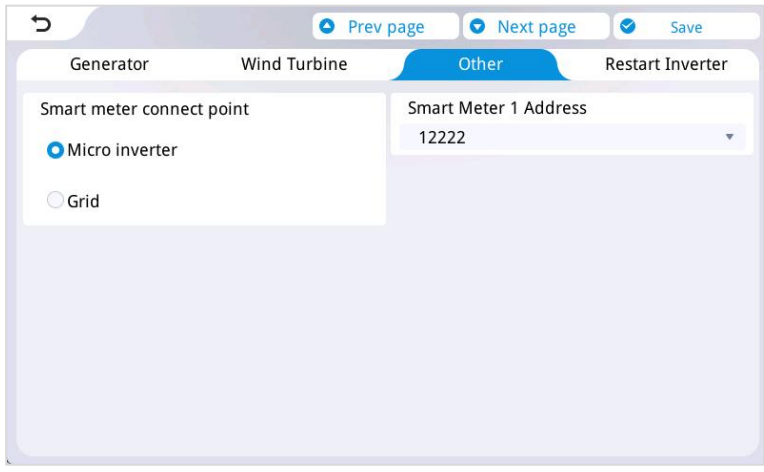

- **MPPT scan:** When this function is enabled: The inverter will perform an MPPT global scan every 30 min. During the scan, the photovoltaic power will drop to 0W and then reach the maximum power point.

Note: Applicable to scenarios where the photovoltaic panels cannot output maximum power due to shading or other reasons.

- **Smart meter connect point:** Select the corresponding object based on the power to be collected by the meter.
 - ① When the meter is required to collect micro-inverter power, select "Micro inverter" (valid only when the micro-inverter is connected to the grid side);
 - ② When the meter is required to collect grid power, select "Grid".
- **Smart Meter 1 Address**
- **AFCI check threshold:** AFCI sensitivity setting range: 0-100.
0: AFCI disabled; 1-100: AFCI enabled, with higher values indicating lower sensitivity.
- **Arc fault clear**

5.2.5.4 Restart Inverter

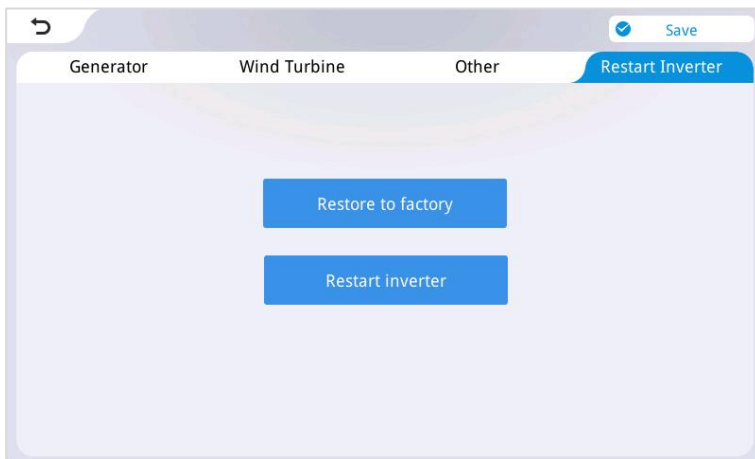

- **Restore to factory:** Reset all inverter settings.
- **Restart inverter:** Restart the inverter.

5.2.6 WiFi Setup

Important Note: In the current version, the WiFi function is only used for screen program upgrade.

5.2.6.1 Search and Select Network

Click the [Refresh] button, select the target network name from the hotspot list, and click to enter the password input interface.

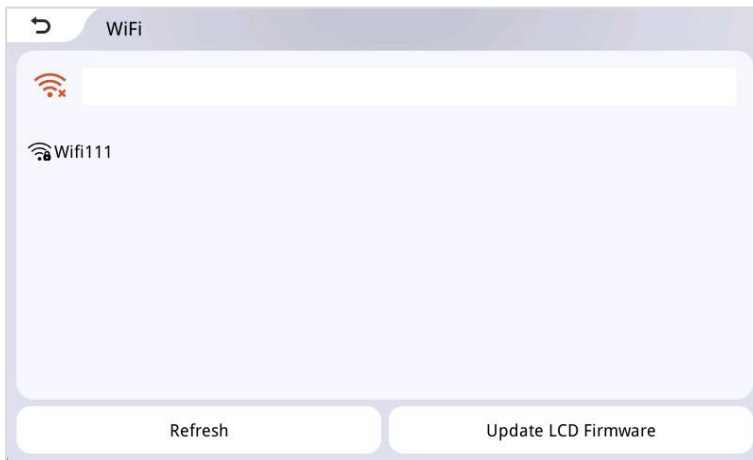

- **Refresh:** Refresh the WiFi network to obtain WiFi hotspots.
- **Update LCD Firmware:** Update the LCD display firmware.

5.2.6.2 Enter and Verify Password

Enter the WiFi network password (supporting numbers and letters) in the password input field; click [Connect] to confirm and establish the connection.

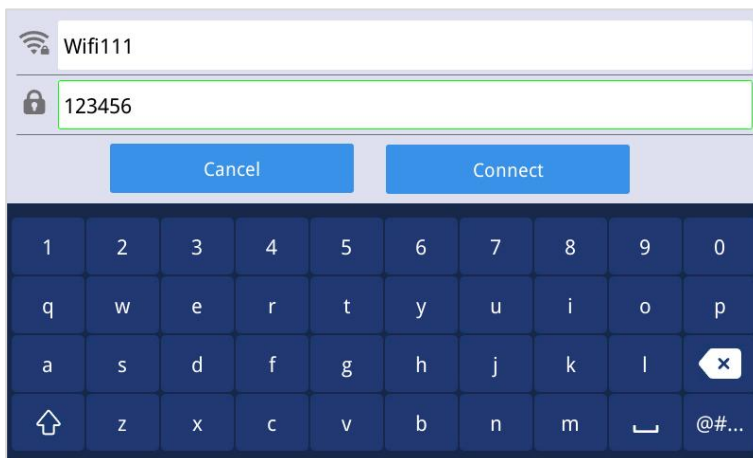

- **Cancel:** Exit the password data interface.
- **Connect:** Connect to the WiFi network.

5.2.7 Firmware Upgrade via USB Drive

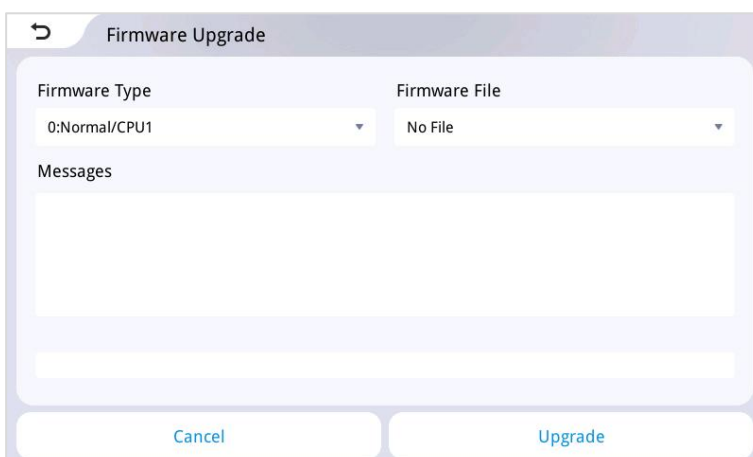

- **Firmware Type:**
 - ① Firmware type.
 - ② 0: Normal/CPU1
 - ③ 1: CPU2
 - ④ 2: AUX DSP
 - ⑤ 3: AFCI MCU
 - ⑥ 4: BMS MCU
- **Firmware File:** Firmware file in the USB drive.
- **Cancel:** Cancel the upgrade.
- **Upgrade:** Update the firmware.

5.3 Time-slot Charging/Discharging Function

The IESP SH3 series have the function of charging and discharging by different time periods. Users can set different charging and discharging time periods according to the local peak and valley electricity prices, so as to make rational use of the utility power and photovoltaic energy. When the utility power price is expensive, the battery inverter can be used to supply electricity to the load. When the utility power price is low, the utility power can be used to supply power to the load and charge the battery, which can help users save electricity bills to the greatest extent. The function of charging and discharging by different time periods, refer to Section 5.2.2.2.

Before using this function for the first time, please refer to Section 5.2.1.1 to set the local time. Users can set corresponding time periods according to the electricity prices during peak and off-peak hours in the local area.

Peak-Valley Electricity Tariff

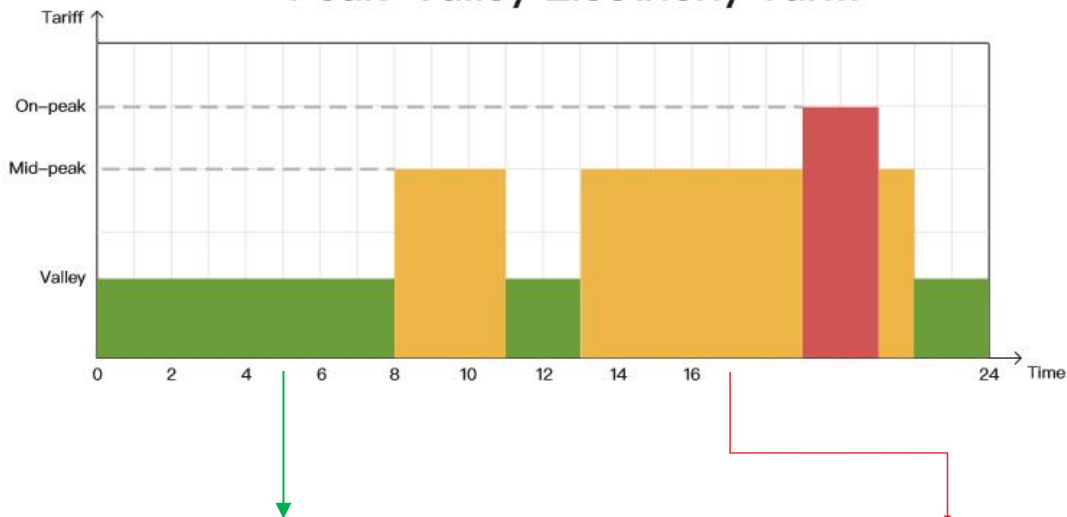

Time-slot Utility Charging & Loading Function



With 3 definable periods, the user can freely set the mains charging/supplying power time within the range of 00:00 to 23:59. During the time period set by the user, if PV energy is available, PV energy will be used first, and if PV energy is not available or insufficient, utility energy will be used as a supplement.

Time-slot Battery Discharging Function

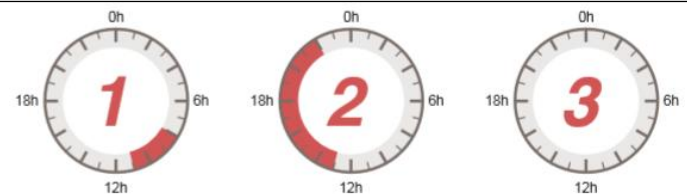

With 3 definable time periods, users can freely set the battery discharge time within the range of 00:00 to 23:59. During the time set by the user, the inverter will give priority to the battery inverter to carry the load, and if the battery power is insufficient, the inverter will automatically switch to mains power to ensure stable operation of the load.

5.4 Battery Parameters

5.4.1 Lead-acid Battery

Battery type Parameters	Sealed lead acid battery (SLD)	Gel lead acid battery (GEL)	Flooded lead acid battery (FLD)	User-defined (USE)	Adjustable
Overvoltage Disconnect Voltage	60V	60V	60V	60V	
Battery fully charged recovery point	52V	52V	52V	52V	√
Boost Charging Voltage	-	-	-	40 ~ 60V	√
Undervoltage Alarm Voltage	44V	44V	44V	40 ~ 60V	√
Undervoltage Alarm Recovery Voltage	Undervoltage alarm voltage+0.8V				
Low Voltage Disconnect Voltage	42V	42V	42V	40 ~ 60V	√
Low Voltage Disconnect Recovery Voltage	52V	52V	52V	52V	√
Discharge Limit Voltage	-	-	-	40 ~ 60V	√
Over-discharge Delay Time	5s	5s	5s	1 ~ 30s	√
Boost Charge Duration	-	-	-	10 ~ 900 min	√

5.4.2 Lithium-ion Battery

Battery type Parameters	Ternary (N13)	Ternary (N14)	LFP (L16)	LFP (L15)	LFP (L14)	Adjustable
Overvoltage Disconnect Voltage	60V	60V	60V	60V	60V	
Battery Fully Charged Recovery Point	50.4V	54.8V	53.6V	50.4V	47.6V	√
Equalization Charging Voltage	-	-	-	-	-	√
Boost Charging Voltage	53.2V	57.6V	56.8V	53.2V	49.2V	√
Undervoltage Alarm Voltage (Fault 01)	43.6V	46.8V	49.6V	46.4V	43.2V	√
Undervoltage Alarm Recovery Voltage (Fault 01)	Undervoltage alarm voltage+0.8V					
Low Voltage Disconnect Voltage (Fault 04)	38.8V	42V	48.8V	45.6V	42V	√
Low Voltage Disconnect Recovery Voltage (Fault 04)	46V	49.6V	52.8V	49.6V	46V	√
Discharge Limit Voltage	36.4V	39.2V	46.4V	43.6V	40.8V	√

Over-discharge Delay Time	30s	30s	30s	30s	30s	√
Boost Charge Duration	120 min	120 min	120 min	120 min	120 min	√

6.Communication

6.1 Product Overview

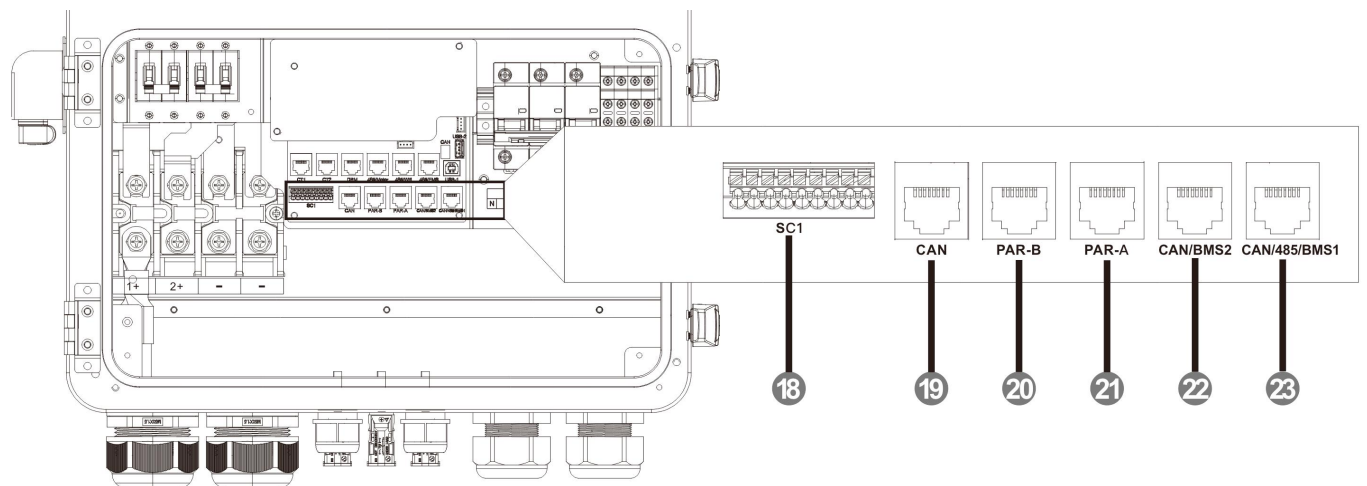
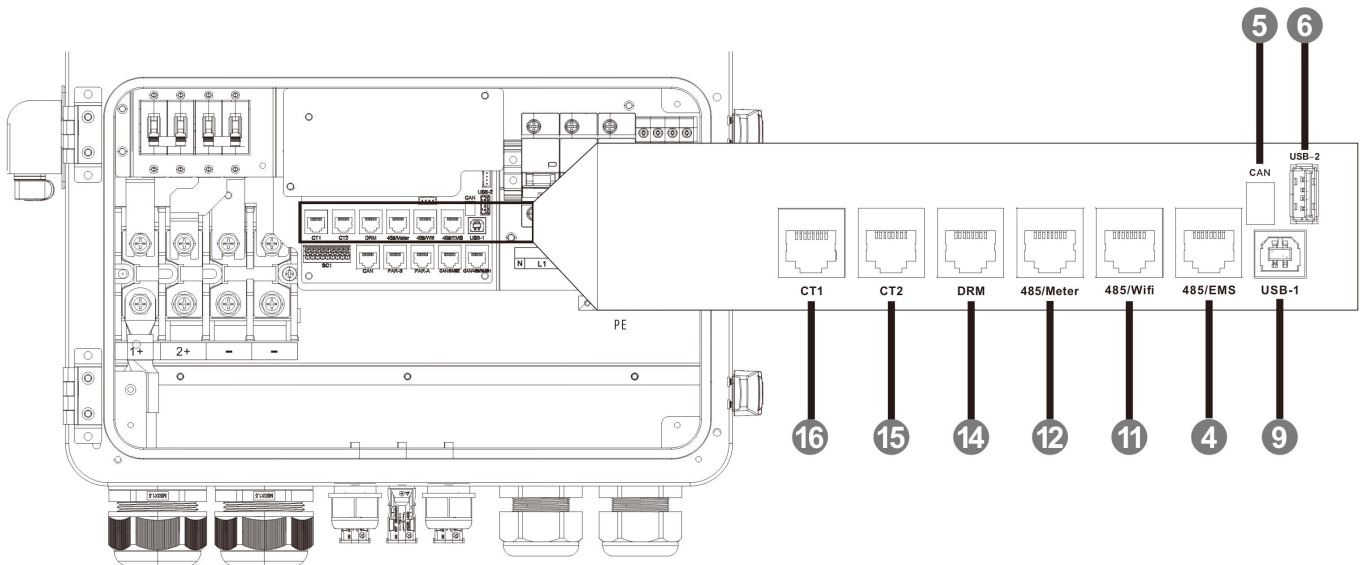

4	485/EMS Port	5	Paralleling DIP Switch	6	Display USB-2
11	485/WiFi Port	12	485/Meter Port	14	DRM Port
15	Micro-inverter CT2	16	Grid CT1	18	Dry Contact Interface SC1
19	CAN2 Communication Port	20	Paralleling Port -B	21	Paralleling Port -A
22	CAN2/BMS2 Communication Port	23	CAN3/485/BMS1 Communication Port		

6.2 USB-1 Port

The user can read and modify device parameters through this port by using the host software. Please contact us for the host software installation package if you require one.

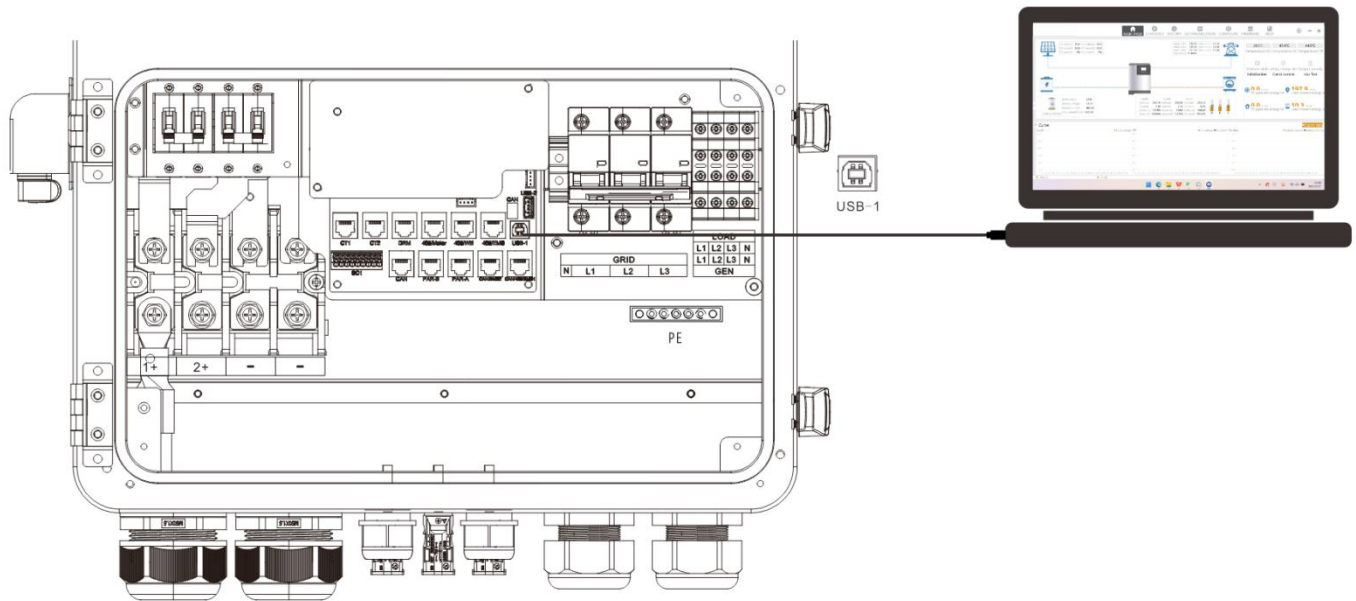

6.3 WiFi Communication Function

The WiFi port is used to connect to the Wi-Fi/GPRS logger module, which allows users to view the operating status and parameters of the inverter via mobile phone APP.

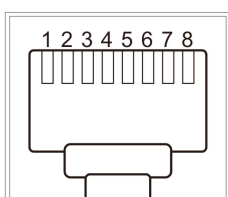
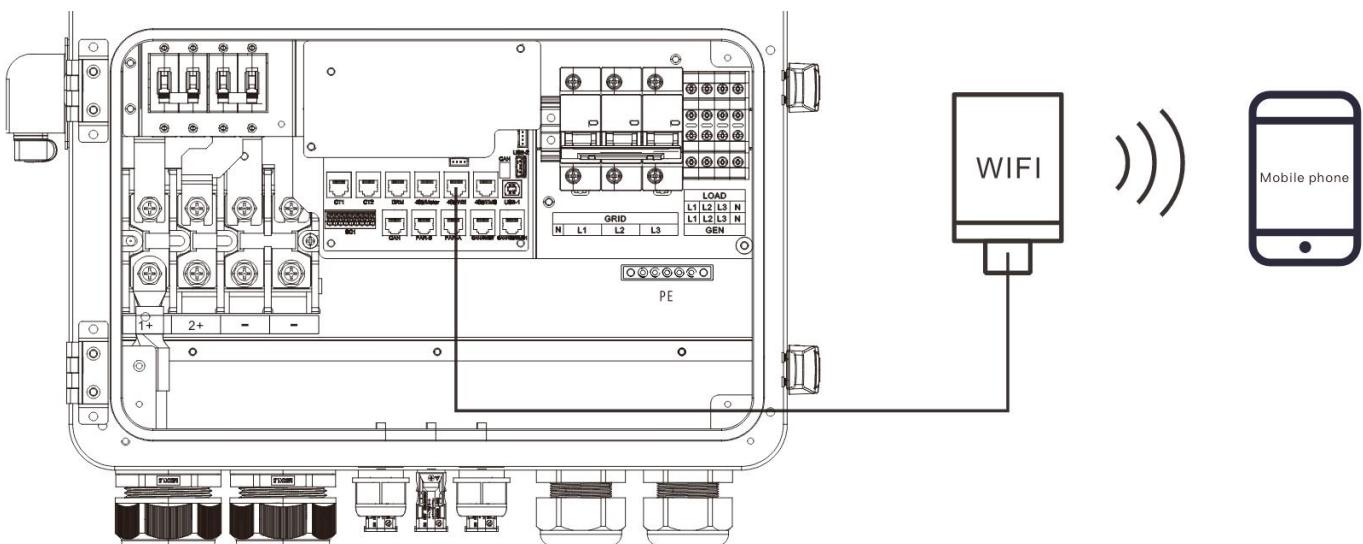

485/WIFI

RJ45	Pin 1	Pin 2	Pin 3	Pin 4	Pin 5	Pin 6	Pin 7	Pin 8
Definition	5V	GND	/	/	/	/	RS485-A	RS485-B

6.4 RS485 Port

The RS485/CAN interface is used to connect to the BMS lithium battery.

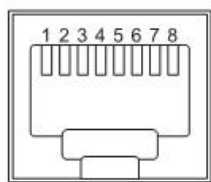

RS485

RJ45	Pin 1	Pin 2	Pin 3	Pin 4	Pin 5	Pin 6	Pin 7	Pin 8
Definition	RS485-B	RS485-A	/	CANH	CANL	/	RS485-A	RS485-B

NOTICE

If you need to use the inverter to communicate with the lithium battery BMS, please contact us for the communication protocol or upgrade the inverter to the appropriate software programme.

6.5 CAN Port

The CAN port is used to connect to the BMS of Liion battery.

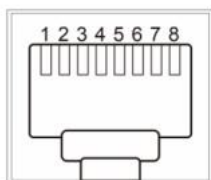

CAN

RJ45	Pin 1	Pin 2	Pin 3	Pin 4	Pin 5	Pin 6	Pin 7	Pin 8
Definition	/	/	/	CANH	CANL	/	/	/

6.6 Display Port USB-2

It is used to updated the screen firmware.

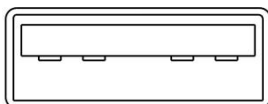

6.7 DRM(Only Australia)

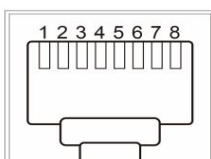

DRM

RJ45	Pin 1	Pin 2	Pin 3	Pin 4	Pin 5	Pin 6	Pin 7	Pin 8
Definition	DRM5	DRM6	DRM7	DRM8	RefGen	COM/ DRM0	V+	V-

MODEL	RJ45 socket asserted by shorting pins		Requirement
	Pin 1	Pin 2	
DRM0	6	5	Operate the disconnection device.
DRM5	1	5	Do not generate power to grid.
DRM6	2	5	Do not generate at more than 50% of rated power.
DRM7	3	5	Do not generate at more than 75% of rated power AND Sink reactive power if capable.
DRM8	4	5	Increase power generation (subject to constraints from other active DRM) .

6.8 External CT Prot

⚠ Important Note: CT1 is used for grid-side current monitoring and must be reliably connected to the main grid circuit to ensure matching with system electrical parameters; CT2 should be accurately connected to the AC output terminal of the micro-inverter for real-time monitoring of the inverter's current output status.

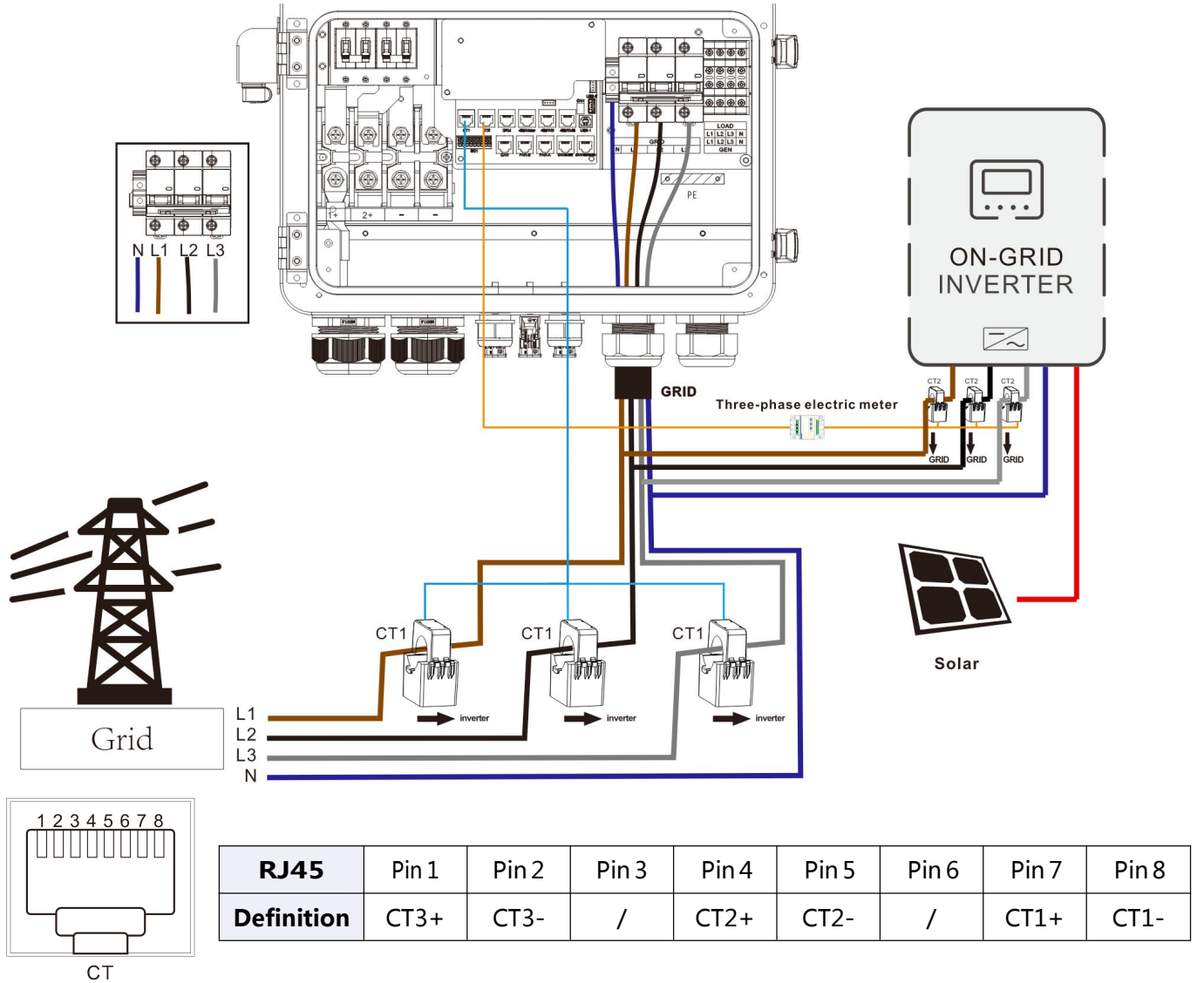

- 1.Split Core Current Transformer (CT) dimension: (mm)
- 2.Secondary output cable length is 4m.

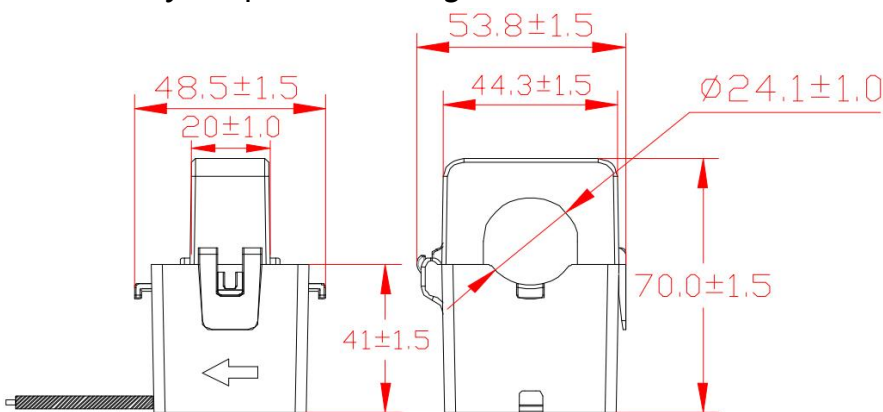

6.9 DIP Switch Configuration

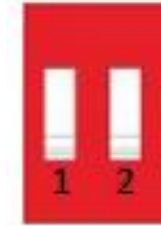

This DIP switch is a resistor matching switch for parallel communication. When performing parallel CAN communication, the first and last units in the parallel system must have DIP switches 1 and 2 set to the up position.

6.10 Dry Contact Function

The dry contact port has 5 functions:

- ① Generator remote start/stop
- ② Temperature sampling (reserved)
- ③ RSD power supply
- ④ Remote signal transmission
- ⑤ Remote signal reception

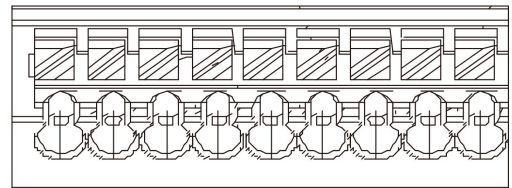

1 2 3 4 5 6 7 8 9

Function	Definition
Remote start/stop of the generator	1-2: NC; 1-3: NO Remote generator shutdown: Pins 1 to 3 are normally opened; pins 1 to 2 are normally closed.
Temperature sampling (reserved)	Pins 9 and 5 can be used for battery temperature sampling compensation.
RSD power supply	Pin 9 is GND, pin 4 is RSD 12V+.
Remote signal transmission	Pins 9 and 7/8: DSP internal signal transmission.
Remote signal reception	Pins 9 and 6: DSP internal signal reception.

NOTICE

If you need to use the remote start/stop function of the generator with dry contact, ensure that the generator has ATS and supports remote start/stop.

6.11 Remote Monitoring

When operating the equipment, it is recommended to enable a remote monitoring configuration.

The inverter supports APP application to provide more comprehensive and intuitive monitoring of power plant data, creating the ultimate user experience with extremely simplified product design thinking to meet the convenient operation of offline applications.

6.11.1 Download App

- **App Download:** Android system can search "SOLARMAN Smart " through application market/store for downloading, while IOS system can choose to download SOLARMAN Smart APP in Apple Store.
- **QR code download:** SOLARMAN Smart APP can also support scanning QR code with mobile phone for downloading. Please scan the code with mobile phone.



6.11.2 Stick Logger Installation

Step1: Install the fixed bracket on the wall next to the inverter.

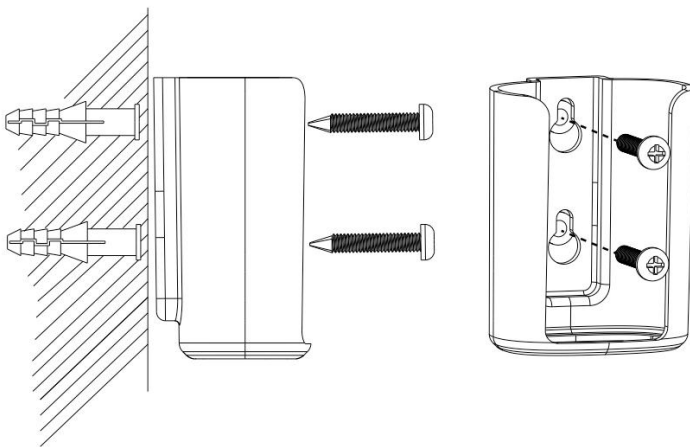

Step2: Connect inverter with data logger, and tighten it.

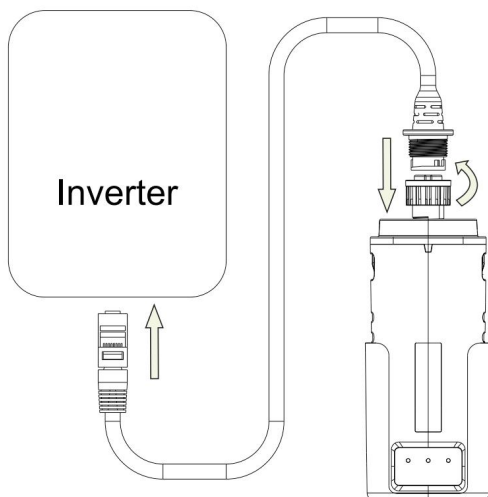

The normal operation status of the stick logger, when router connected to the network normally:

- ① Connection to the server succeeded: NET light keeps on after the logger powered on.
- ② Logger running normally: READY light flashes.
- ③ Connection to the inverter succeeded: COM light keeps on.

6.11.3 SOLARMAN Smart APP Operation

Please make sure Bluetooth and WiFi are ON and the router can connect to the network normally.

■ Registration

Go to SOLARMAN Smart and register.

Click "Register" and create an account here.

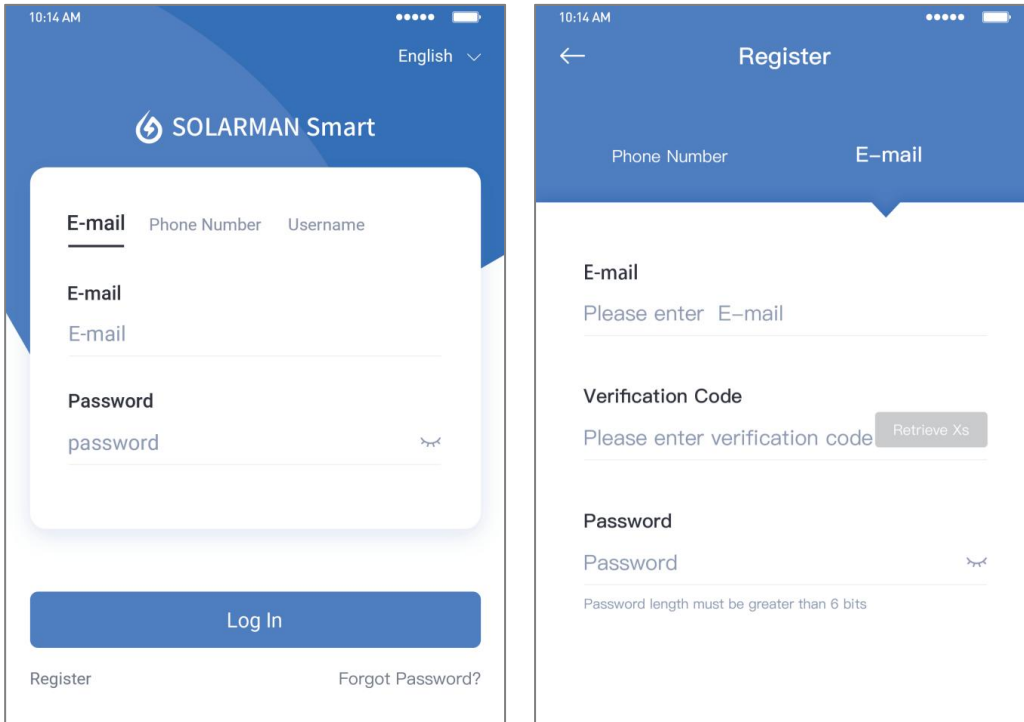

The first screenshot shows the SOLARMAN Smart app interface. At the top, there is a language selector set to "English". Below the app logo, there are three tabs: "E-mail", "Phone Number", and "Username". The "E-mail" tab is selected. There are two input fields: "E-mail" and "Password" (containing the text "password"). A blue "Log In" button is at the bottom. Below the button are links for "Register" and "Forgot Password?".

The second screenshot shows the "Register" screen. It has a back arrow and the title "Register". There are two tabs: "Phone Number" and "E-mail", with "E-mail" selected. The form includes:

- An "E-mail" field with the placeholder text "Please enter E-mail".
- A "Verification Code" field with the placeholder text "Please enter verification code" and a "Retrieve Xs" button.
- A "Password" field with the placeholder text "Password" and a "Password length must be greater than 6 bits" note below it.

■ Create a Plant

Click "Add Now" to create your plant.

Please fill in plant basic info and other info here.

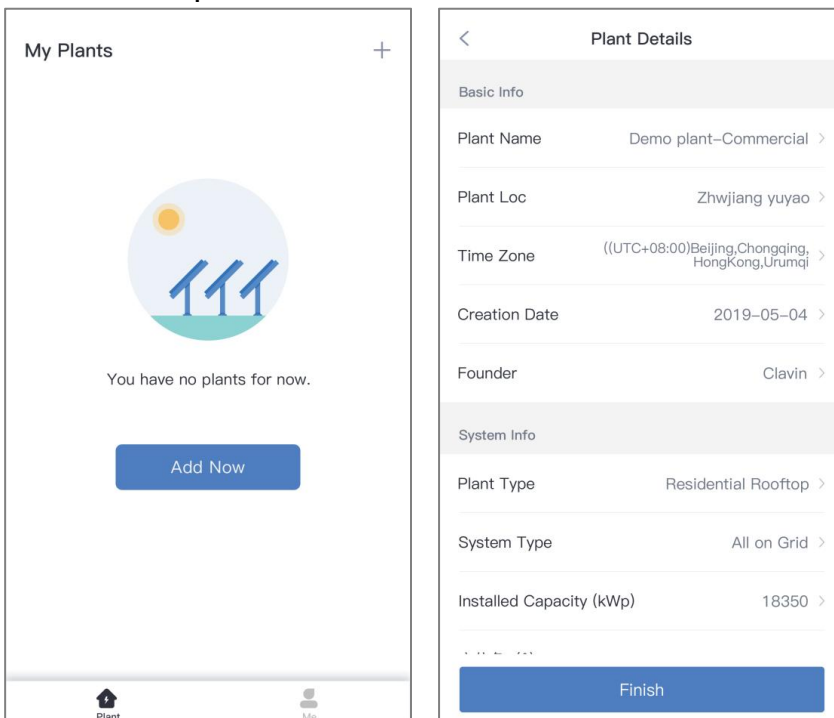

The first screenshot shows the "My Plants" screen. It has a title "My Plants" and a "+" icon. Below is a circular icon representing solar panels. The text "You have no plants for now." is displayed. A blue "Add Now" button is at the bottom. The bottom navigation bar shows "Plant" and "Me" icons.

The second screenshot shows the "Plant Details" form. It has a back arrow and the title "Plant Details". The form is divided into two sections:

- Basic Info:**
 - Plant Name: Demo plant-Commercial >
 - Plant Loc: Zhwjiang yuyao >
 - Time Zone: ((UTC+08:00)Beijing,Chongqing, HongKong,Urumqi) >
 - Creation Date: 2019-05-04 >
 - Founder: Clavin >
- System Info:**
 - Plant Type: Residential Rooftop >
 - System Type: All on Grid >
 - Installed Capacity (kWp): 18350 >

 A blue "Finish" button is at the bottom.

■ Add a Logger

Method 1: Enter logger SN manually.

Method 2: Click the icon in the right and scan to enter logger SN

You can find logger SN in the external packaging or on the logger body

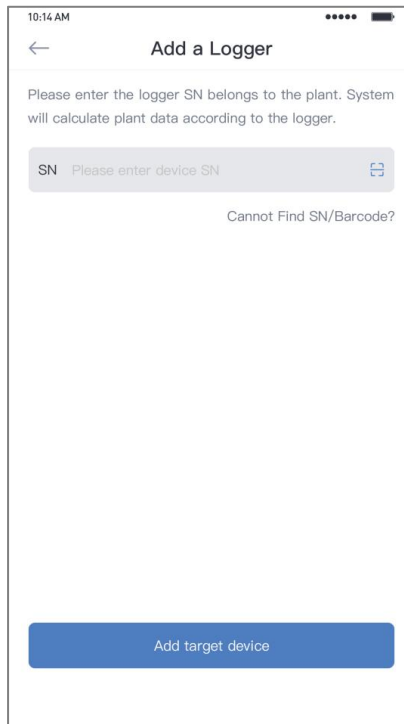
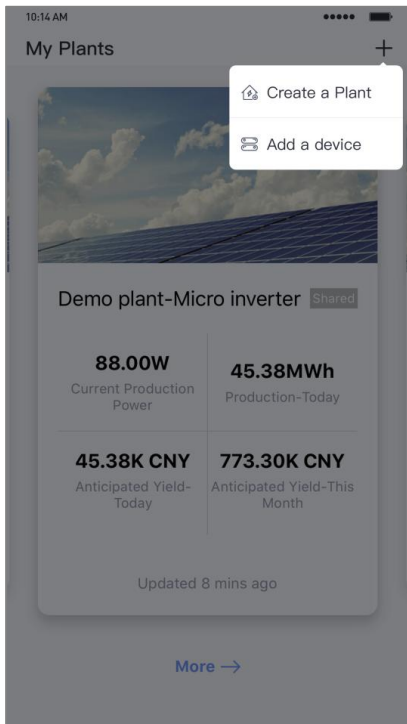

■ Network Configuration

Step 1: Click "Go to Configure" to set the network. (Please make sure Bluetooth and WiFi are ON.)

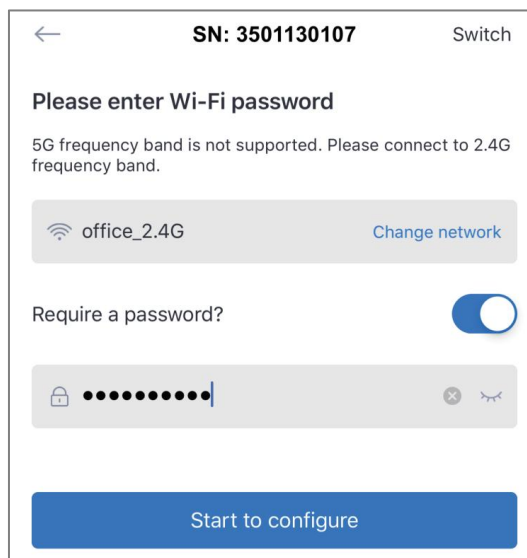
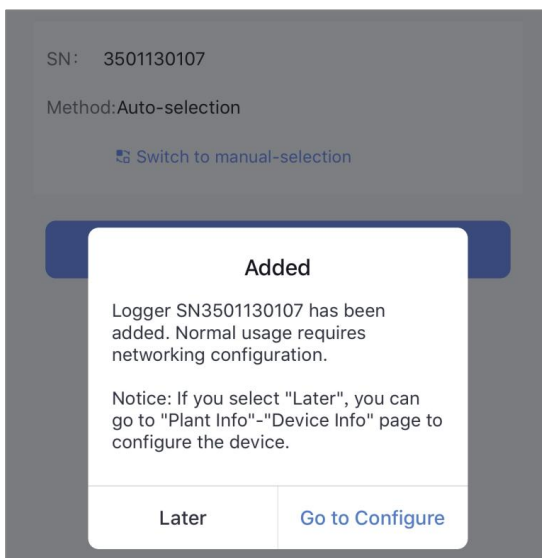

Step 2: Please wait for a few minute. Then click "Done" and view plant data.

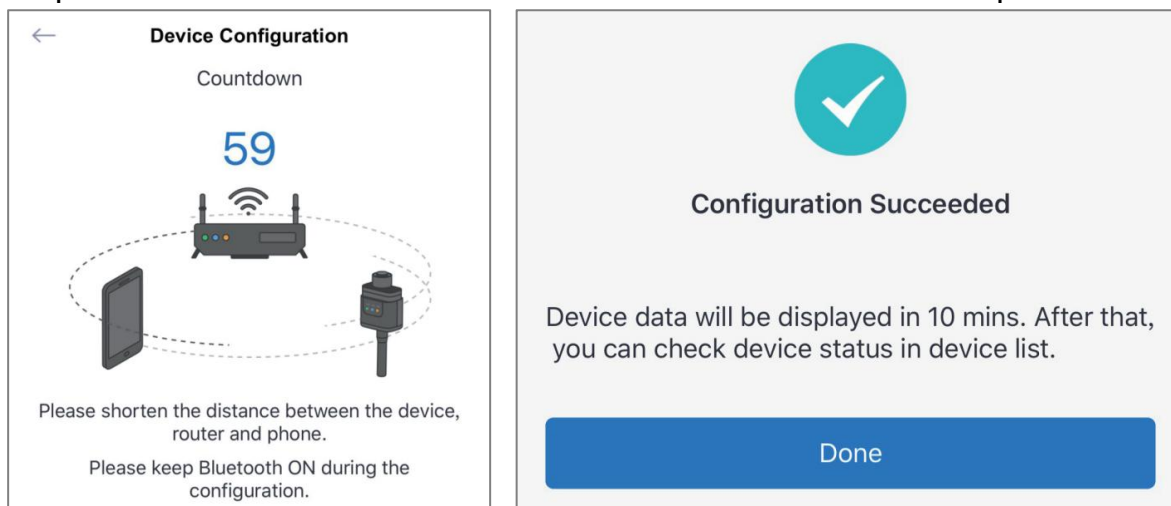

 **NOTICE**

If configuration failure occurs, please check the following reason and try it again.

- Make sure WLAN is ON.
- Make sure WiFi is normal.
- Make sure wireless router does not implement the white-black list.
- Remove the special characters in Wi-Fi network.
- Shorten the distance between the phone and device.
- Try to connect to other Wi-Fi.

6.11.4 Plant Detail



After the photovoltaic plant is created and connected to the Logger, you can select the plant to view the corresponding plant data and related settings, including Real time, Statistical, Device, Alerts, Plant Info and Layout, so as to meet the end user's maintenance of plant information and data browsing.

Note: In general, the Plant data can be viewed normally only after 5-10 minutes after the Logger networking configuration is completed.

■ Real-time Data

In the "Real time" interface, you can see the real-time data of the Plant, such as real-time generation power and output, energy flow chart, 24-hour power curve, generation and consumption data, etc. The system will display different page layouts according to your plant grid connection type. Please set your plant according to the actual situation.

Depending on your equipment, we recommend:

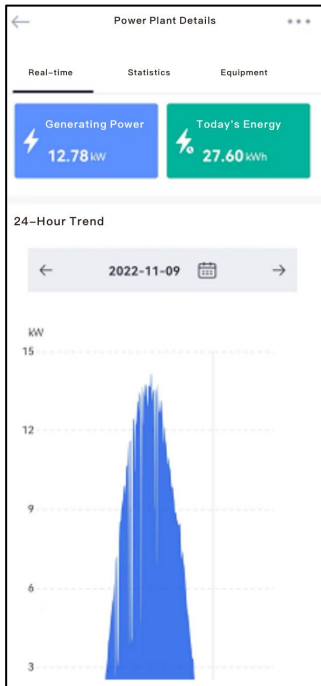

- ① If your equipment (such as inverter) only collects power generation data and transmits it to the grid company, it is recommended that you select "All on Grid" as the System Type of the Plant
- ② If your equipment (such as inverter) collects power generation data and power consumption data at the same time, it is recommended that you select "Self consumption" as the System Type of the Plant
- ③ If your equipment (such as inverter) collects power generation data, power consumption data, battery data and grid data at the same time, it is recommended that you select "Storage System" as the System Type of the Plant.

■ Device info

In the "Device" interface, you can view the device information under plant. Select and click a specific device to view the specific information of the device, including the device parameters, data statistics and connection information. Through these data, you can determine whether the device is in normal working state. It can support networking configuration, meter configuration and other functional operations for the corresponding equipment. If the equipment is a logger, networking configuration can be carried out. If the equipment is an electricity meter, meter configuration can be carried out.

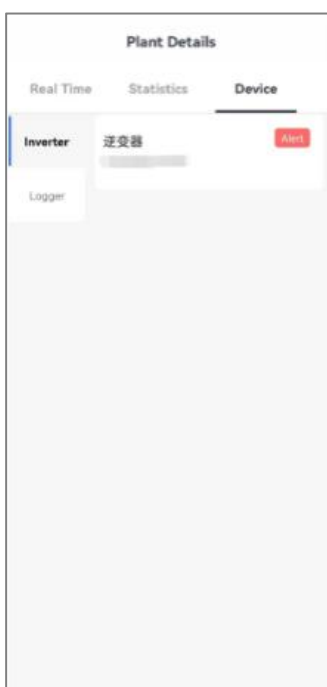

The screenshot shows the 'Device Parameters' for an inverter. It displays a table of electricity generation data and summary statistics.

DC	Voltage	Current	Power
PV1	507.00V	1.90A	963.30W
PV2	514.60V	1.90A	977.74W
PV3	507.00V	1.90A	963.30W
PV4	514.60V	1.90A	977.74W

AC	Voltage	Current	Frequency
R	235.10V	2.70A	50.02Hz
S	233.80V	2.60A	--
T	233.10V	2.60A	--

Total DC Input Power:	3.88kW	Total AC Output Power (Active):	3.90kW
Peak Active Power:	14.15kW	Cumulative Production (Active):	13.47MWh
Daily Production (Active):	84.40kWh		

6.11.5 Abnormal State Processing

If the data on platform is abnormal when the stick logger is running, please check the table below and according to the status of indicator lights to complete a simple troubleshooting. If it still can not be resolved or indicator lights status do not show in the table below, please contact Customer Support.

(Note: Please using the following table query after power-on for 2mins at least.)

NET ● NET	COM ● COM	READY ● READY	Fault Description	Fault Cause	Solution
Any state	OFF	Slow flash	Communicate with inverter abnormally	1.Connection between stick logger and inverter loosen. 2.Inverter does not match with stick logger's communication rate.	1.Check the connection between stick logger and inverter. Remove the stick logger and install again. 2.Check inverter's communication rate to see if it matches with stick logger's. 3.Long press Reset button for 5s, reboot stick logger.
OFF	ON	Slow flash	Connection between logger and router abnormal	1.Stick logger does not have a network. 2.Router WiFi signal strength weak.	1.Check if the wireless network configured. 2.Enhance router WiFi signal strength.
Slow flash	ON	Slow flash	Connection between logger and router normal, connection between logger and remote server abnormal.	1.Router networking abnormal. 2.The server point of logger is modified. 3.Network limitation, server cannot be connected.	1.Check if the router has access to the network. 2.Check the router's setting, if the connection is limited. 3.Contact our customer service.
OFF	OFF	OFF	Power supply abnormal	1.Connection between stick logger and inverter loosen or abnormal. 2.Inverter power insufficient. 3.Stick Logger abnormal.	1.Check the connection, remove the stick logger and install again. 2.Check inverter output power. 3.Contact our customer service.
Fast flash	Any state	Any state	Networking status	Normal	1.Exit automatically after 2mins. 2.Long press Reset button for 5s, reboot stick logger. 3.Long press Reset button for 10s, restore factory settings.
Any state	Any state	Fast flash	Restore factory settings	Normal	1.Exit automatically after 1mins. 2.Long press Reset button for 5s, reboot stick logger. 3.Long press Reset button for 10s, restore factory settings.

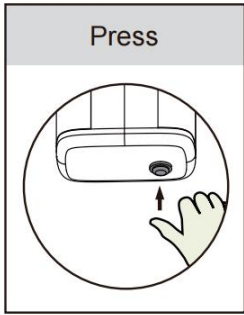

Key-press	Status Description	Light Status
Long press 5s then release	Rebooting the stick logger.	All lights are extinguished immediately.
Long press 10s then release	Resetting the stick logger.	1.All lights are extinguished after 4s. 2.READY light flashes fast for 100ms.

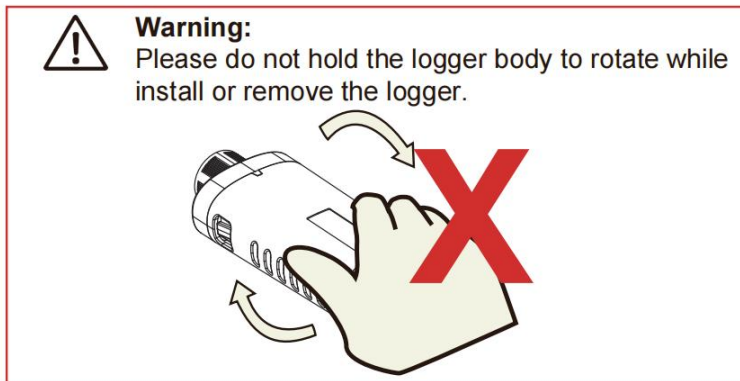

7.Fault and Remedy

7.1 Fault Codes

Fault Code	Fault name	Whether it affects the output or not	Description
01	BatVoltLow	NO	Battery undervoltage alarm.
02	BatOverCurrSw	YES	Battery discharge average current overcurrent (software protection).
03	BatOpen	YES	Battery not-connected alarm.
04	BatLowEod	YES	Battery undervoltage stop discharge alarm.
05	BatOverCurrHw	YES	Battery overcurrent (hardware protection).
06	BatOverVolt	YES	Charging overvoltage protection.
07	BusOverVoltHw	YES	Bus overvoltage (hardware protection).
08	BusVoltSoftErr	YES	Bus overvoltage (software protection).
09	PvVoltHigh	NO	PV overvoltage protection.
10	ArcFault	YES	AFCI Arc fault.

11	PvBoostOCHw	NO	Boost overcurrent hardware protection
12	SpiCommErr	YES	Master-slave SPI communication failure.
13	OverloadBypass	YES	Bypass overload protection.
14	Overload Inverter	YES	Inverter overload protection.
15	AcOverCurrHw	YES	Inverter overcurrent hardware protection.
16	AuxDSpReqOffPWM	YES	Slave chip OFF request fault.
17	InvShort	YES	Inverter short circuit protection.
18	Bussoftfailed	YES	Bus soft-start failure.
19	OverTemperTrans	YES	Transformer radiator over-temperature protection.
20	OverTemperInv	YES	Inverter radiator over-temperature protection.
21	FanFail	YES	Fan failure.
22	EEPROM	YES	Memory failure.
23	Model NumErr	YES	Model setting error.
24	Busdiff	YES	Positive and negative bus voltage imbalance.
25	BusShort	YES	Bus short circuit.
26	Rlyshort	YES	Inverter AC output backfeed to bypass AC output.
27	LinePhaselose	YES	Grid input phase lose.
28	LinePhaseErr	YES	Grid input phase error.
29	BusVoltLow	YES	Low bus voltage protection.
30	BatCapacityLow1	NO	Alarm given when battery capacity rate is lower than 10% (setting BMS to enable validity).
31	BatCapacityLow2	NO	Alarm given when battery capacity rate is lower than 5% (setting BMS to enable validity).
32	BatCapacityLowStop	YES	Inverter stops when battery capacity is low (setting BMS to enable validity).
33	ControlCanFault	YES	Control CAN fault in parallel operation.
34	CanCommFault	YES	CAN communication fault in parallel operation.
35	ParaAddrErr	YES	Parallel ID (communication address) setting error.
36	Balance currentOC	YES	Balanced bridge arm overcurrent fault.
37	ParaShareCurrErr	YES	Current distribution fault in parallel operation.
38	ParaBattVoltDiff	YES	Parallel mode, inconsistent utility input source.
39	ParaAcSrcDiff	YES	Inconsistent AC input source in parallel mode.
40	ParaHwSynErr	YES	Hardware synchronization signal error in parallel mode.
41	InvDcVoltErr	YES	Inverter DC voltage error.
42	SysFwVersionDiff	YES	Inconsistent system firmware version in parallel mode.
43	ParaLineContErr	YES	Parallel line connection error in parallel mode.
44	Serial number error	YES	No serial number set at factory.
45	Error setting of split-phase mode	YES	Item "Parallel" setting error.

46	MeterComErr	YES	Meter communication fault.
47	ChipProgramErr	YES	Chip program unburned fault.
48	AfciSelfCheckErr Or AfciComErr	YES	AFCI module self-test failure or communication failure.
49	Grid over voltage	YES	Grid voltage too high.
50	Grid under voltage	YES	Grid voltage too low.
51	Grid over Frequency	YES	Grid frequency too high.
52	Grid under Frequency	YES	Grid frequency too low.
53	Grid loss	YES	Grid voltage loss.
54	Grid DC current over	YES	Excessive DC component in grid current.
55	Grid standard un init	YES	Grid-Connection standard micro-initialization.
56	Low insulation resistance fault	NO	PV1+, PV2+, PV3+, PV- impedance to ground abnormally low.
57	Leakage current overload fault	YES	System leakage current exceeds the standard.
58	BMSComErr	NO	BMS communication error.
60	BMSUnderTem	NO	BMS low temperature alarm (effective after successful BMS communication).
61	BMSOverTem	YES	BMS over-temperature alarm (effective after successful BMS communication).
62	BMSOverCur	YES	BMS overcurrent alarm (effective after successful BMS communication).
63	BMSUnderVolt	NO	BMS undervoltage alarm (effective after successful BMS communication).

7.2 Troubleshooting

Fault Code	Meaning	Causes	Remedy
/	No screen display	No power input, or the switch on the bottom of the unit is not switched on.	Check whether the battery air circuit-breaker or PV air circuit-breaker is turned on. Check if the switch is "ON". Press any button on the screen to exit the screen sleep mode.
01	Battery under-voltage	Battery voltage is lower than the parameter setting value.	Wait until the battery charge is restored to above the low voltage disconnection recovery voltage.
03	Battery not connected	The battery is not connected, or the BMS is in discharge protection state.	Check that the battery is reliably connected. Check that the battery circuit-breaker is off. Ensure that the BMS is able to communicate properly.
04	Battery over-discharge	The battery voltage is lower than the value set in 【Battery Settings】 - 【Battery Discharge】 - 【Batt. voltage low fault】 .	Manual reset: Turn off and restart. Automatic reset: Charge the battery so that the battery voltage is higher than the voltage set in the parameter item 【Battery Settings】 - 【Battery Discharge】 - 【Battery Recovery Voltage】 .
06	Battery over-voltage when charging	Battery is in over-voltage condition.	Manually power off and restart. Check to see if the battery voltage exceeds the limit. If it exceeds, the battery needs to be discharged until the voltage is below the battery over-voltage recovery point.

13	Bypass over-load (software detection)	Bypass output power or output current over-load for a period of time.	Reduce the load power and restart the device.
14	Inverter over-load (software detection)	Inverter output power or output current over-load for a period of time.	
19	Heat sink of PV input over-temperature (software detection)	Heat sink of PV input temperature exceeds 90°C for 3s.	Normal charging and discharging is resumed when the temperature of the heat sink cools below the over-temperature recovery temperature.
20	Heat sink of inverter output over-temperature (software detection)	Heat sink of inverter output temperature exceeds 90°C for 3s.	
21	Fan failure	Hardware detects fan failure.	Manually toggle the fan after powering off the machine to check for foreign matter blockage.
26	AC input relay short-circuit	Relay for AC input sticking.	Manually turn off and restart the machine, if the fault reappears after restarting, you need to contact the after-sales service to repair the machine.
28	Utility input phase fault	AC input phase does not match AC output phase.	Make sure that the phase of the AC input is the same as the phase of the AC output.

NOTICE

If you encounter product faults that cannot be solved by the methods in the above table, please contact our after-sales service department for technical support and do not disassemble the equipment by yourself.

8. Protection and Maintenance

8.1 Protection Functions

No.	Protection Functions	Description
1	PV input current limiting protection	When the charging current or power of the PV array configured exceeds the PV input rated value, the inverter will limit the input power and charge at the rated.
2	PV input over-voltage	If the PV voltage exceeds the maximum value allowed by the hardware, the machine reports a fault and stops PV boosting to output a sinusoidal AC waveform.
3	Anti-reverse charge protection at night	At night, the battery will be prevented from discharging to the PV module because the battery voltage is greater than the PV module voltage.
4	AC input over-voltage protection	When the mains voltage of per phase exceeds 280Vac, the mains charging will be stopped and will switch to inverter output.
5	AC input under-voltage protection	When the mains voltage of per phase falls below 170Vac, the mains charging will be stopped and will switch to inverter output.
6	Battery over-voltage protection	When the battery voltage reaches the over-voltage disconnection voltage point, it will automatically stop the PV and mains charging of the battery to prevent over-charging and damage to the battery.
7	Battery under-voltage protection	When the battery voltage reaches the low-voltage disconnection voltage point, it will automatically stop discharging the battery to prevent the battery from being over-discharged and damaged.
8	Battery over-current protection	When the battery current exceeds the range allowed by hardware, the machine will turn off output and stop discharging the battery.

9	AC output short-circuit protection	When a short-circuit fault occurs at the load, the AC output voltage will be switched off immediately and output again after 1 min. If the output load is still short-circuited after 3 attempts, short-circuit fault of the load must be eliminated first and then manually re-powered in order to restore the normal output.
10	Heat sink over-temperature protection	When the internal temperature of the inverter is too high, the inverter will stop charging and discharging; when the temperature returns to normal, the inverter will resume charging and discharging.
11	Overload Protection	<p>Three-phase overload logic: After triggering overload protection, the inverter resumes output after 3 min. If overload occurs five consecutive times, output is shut off until the inverter is restarted.</p> <p>(102% < load < 110%): Alarm, output shuts off after 5 min. (110% < load < 125%): Alarm, output shuts off after 20 seconds. (125% < load < 200%): Alarm, output shuts off after 10 seconds.</p> <p>Single-phase overload logic: 1.5 × (102% < load < 110%): Alarm, output shuts off after 5 min. 1.5 × (load > 110%): Alarm, output shuts off after 10 seconds.</p>
12	AC output reverse	Prevents backfeeding of battery inverter AC to bypass AC inputs.
13	Bypass over-current protection	Built-in AC input overcurrent protection circuit breaker.
14	Bypass phase inconsistency protection	When the phase of the two bypass inputs is different from the phase of the inverter phase split, the machine will prohibit cutting into the bypass to prevent the load from dropping out or short-circuiting when cutting into the bypass.
15	Arc fault circuit interrupter protection (AFCI)	Its primary function is to detect whether electric arcs occur in the wires between the PV modules and the inverter, as well as between PV modules themselves, due to aging or other factors. This protection mechanism prevents fire hazards caused by electric arcs; once an arc is detected, the inverter will immediately shut down its operation to activate protective measures.
16	Anti-Islanding protection	It serves as a safety switch for the power system. When the grid suffers a sudden power outage, it will quickly disconnect the inverter from the grid, preventing the formation of an island and ensuring the safety of maintenance personnel as well as the normal operation of the equipment.

8.2 Maintenance

To maintain optimum long-lasting working performance, it is recommended that the following items be checked twice a year.

- Ensure that the airflow around the inverter is not blocked and remove any dirt or debris from the radiator.
- Check that all exposed conductors are not damaged by sunlight, friction with other surrounding objects, dry rot, insect or rodent damage, etc. The conductors need to be repaired or replaced if necessary.
- Verify that the indications and displays are consistent with the operation of the equipment, note any faults or incorrect displays and take corrective action if necessary.
- Check all terminals for signs of corrosion, insulation damage, high temperatures or burning/discolouration and tighten terminal screws.
- Check for dirt, nesting insects and corrosion, clean as required, clean insect screens regularly.
- If the lightning arrester has failed, replace the failed arrester in time to prevent lightning damage to the inverter or other equipment of the user.

DANGER

Make sure that the inverter is disconnected from all power sources and that the capacitors are fully discharged before carrying out any checks or operations to avoid the risk of electric shock.

8.3 Storage

If the inverter is not to be put into use immediately, the following requirements shall be met for storage:

- Do not remove the original packaging of the inverter.
- The storage temperature shall be maintained at $-40^{\circ}\text{C} \sim +70^{\circ}\text{C}$; the relative humidity shall be maintained at 5% RH \sim 95% RH.
- Store in a clean and dry place to protect against dust and moisture erosion.
- Maximum stacking height: 4 layers. When stacking, place the inverters with care to prevent tipping over, which may cause personal injury or equipment damage.
- Conduct regular inspections during storage (recommended once every three months). Replace the packaging materials in a timely manner if moth damage, rat bites or packaging damage is found.
- If the storage period is 2 years or longer, the inverter must be inspected and tested by professional personnel before being put into use.

9.Datasheet

Models	HESP48160SH3	HESP48180SH3	HESP48200SH3	Adjustable
Inverter Output (Load)				
Rated Output Power	16000W	18000W	20000W	
Max. Peak Power	32000VA	36000VA	40000VA	
Rated Output Voltage	230/400Vac (L1+L2+L3+N+PE)			Y
Output Voltage Error	$\pm 5\%$			
Load Motor Capacity	10HP	11HP	12HP	
Rated Frequency	50/60Hz $\pm 0.3\text{Hz}$			Y
Waveform	Pure sine wave			
Switch Time	10ms (Typical)			
Overload Protection	<p>Three-phase overload logic: After triggering overload protection, the inverter resumes output after 3 min. If overload occurs five consecutive times, output is shut off until the inverter is restarted. (102% < load < 110%): Alarm, output shuts off after 5 min. (110% < load < 125%): Alarm, output shuts off after 20 seconds. (125% < load < 200%): Alarm, output shuts off after 10 seconds.</p> <p>Single-phase overload logic: 1.5 \times (102% < load < 110%): Alarm, output shuts off after 5 min. 1.5 \times (load > 110%): Alarm, output shuts off after 10 seconds.</p>			

AC Output (On-grid)				
Rated Output Power	16000W	18000W	20000W	
Max. Apparent Power	32000VA	36000VA	40000VA	
Power Factor	0.8 leading to 0.8 lagging			
Rated Output Voltage	230/400Vac (L1+L2+L3+N+PE)			
Rated AC Frequency	50/60Hz			
Rated AC Output Current	23.2Aac	26.1Aac	29Aac	
THD	<3%			
Battery Data				
Battery Type	Lithium-ion Battery / Lead-acid Battery / User-defined			Y
Rated Battery Voltage	48Vdc			
Battery Voltage Range	40-60Vdc			
Max. Generator Charging Current	300Aac	330Aac	350Aac	Y
Max. Grid Charging Current	300Aac	330Aac	350Aac	Y
Max. Hybrid Charging Current	300Aac	330Aac	350Aac	Y
PV Input				
No. of MPPT Trackers	3			
Max. PV Input Power	24000W	27000W	30000W	
Max. PV Input Current	26A + 26A + 26A			
Max. Short-circuit Current	45A + 45A + 45A			
Max. Open Circuit Voltage	1000V			
MPPT Operating Voltage Range	160V ~ 800V			
Grid/Generator Input				
Input Voltage Range	Phase Voltage: 170V~280V; Line Voltage: 305V~485V			
Input Frequency Range	50/60Hz			
Bypass Overload Current	70A			
Efficiency				
MPPT Tracking Efficiency	99.9%			
Max. Efficiency	≥97.8%			
European Efficiency	97.2%	97.5%	97.5%	
Protections				
PV Input Lightning Protection	Yes			
Anti-islanding Protection	Yes			
PV String Input Reverse Polarity Protection	Yes			
Insulation Resistor Detection	Yes			
Residual Current Monitoring	Yes			

Unit		
Output Over Current Protection	Yes	
Output Shorted Protection	Yes	
Surge Protection	DC type II/AC type II	
Overvoltage Category	DC type II/AC type III	
Certification		
On-grid Standard	EN50549,VDE4105	
Safety	IEC62109-1, IEC62109-2	
EMC	EN61000-6-1, EN61000-6-3, FCC 15 class B	
RoHS	Yes	
Basic Data		
Parallel Capacity	9	
Operating Temperature	-25 ~ 60°C, >45°C derated	
Humidity Range	0 ~ 100%	
Noise	<60dB	
Protection Degree	IP65	
Cooling Method	Heat sink + intelligent air cooling	
Standby Power Consumption	<100W	
Dimensions	800x470x313mm	
Weight	59.5kg	
Communication Interface	RS485 / CAN / USB / Dry contact	Y
External Modules (Optional)	Wi-Fi / 4G Stick	Y



SRNE Solar Co.,Ltd

Mail master@szshuori.com

Web www.srnesolar.com

Address 4-5F,Building13A,Taihua Wutong Industrial
Park ,Gushu Development Zone ,
Hangcheng Street,Baoan, Shenzhen,
China PR

